



TRC-500

Tone Remote Controller with Motorola's MDC-1200 ANI Decoding

Manual Revision: 2012-07-27

Covers TRC Firmware Revisions:
1.22 & Higher

Covers Keyboard Firmware Revisions:
3.2 & Higher

Covers Encoder/Decoder Firmware Revisions:
5.0 & Higher

Covers PCB Revisions:
G & Higher

TABLE OF CONTENTS

Specifications	3
General Information	4
Hardware Installation	5
Hardware Alignment	7
Jumper Settings	9
Controls & Indicators	10
Operation	12
Product Programming	15
Tone Signaling Formats	25
System Error Messages	27
Theory of Operation	29
Technical Notes	31
Contact Information	31

SPECIFICATIONS

Voltage/Current:

Operating Voltage:	18 VDC
Operating Current (standby):	210 mA
Operating Current (RX):	380 mA
Operating Current (TX):	220 mA

RX Inputs:

Input Impedance (RX):	600 Ohms
Compression Threshold:	Adjustable to -20 dbm
Compression Range:	Not more than 3 db change for 30 db increase above threshold
Speaker Audio Output:	2.0 Watt
Distortion:	Less than 3% at full audio
Hum & Noise:	50 db below normal operating level
Frequency Response:	Less than 3 db from 300 Hz-3 KHz
Notch Filter Depth:	45 db relative to 1 KHz below compression

TX Outputs:

TX Output:	Adjustable to +15 dbm on 2175 Hz
Output Impedance (TX):	600 Ohms
Mic Compression Threshold:	Adjustable typically 50 mv
Compression Range:	Not more than 3 db change for 30 db increase above threshold
Hum & Noise:	50 db below normal operating level
Notch Filter Depth:	45 db relative to 1 KHz below compression

Mechanical:

Dimensions:	2.875" H x 6.5" W x 8.75" L
Operating Temp (excluding LCD):	-30° to +60° C

Default Control Tone Frequencies & Timing:

Function Tone	Frequency	Level & Duration	Function Tone	Default	Level & Duration
High-Level Guard	2175 Hz	10 dBm for 120 msec	F8	1250 Hz	0 dBm for 40 msec
Low-Level Guard	2175 Hz	-20 dBm continuous	F9	1150 Hz	0 dBm for 40 msec
Monitor	2050 Hz	0 dBm for 40 msec	F10	1050 Hz	0 dBm for 40 msec
F1	1950 Hz	0 dBm for 40 msec	F11	950 Hz	0 dBm for 40 msec
F2	1850 Hz	0 dBm for 40 msec	F12	850 Hz	0 dBm for 40 msec
F3	1750 Hz	0 dBm for 40 msec	F13	750 Hz	0 dBm for 40 msec
F4	1650 Hz	0 dBm for 40 msec	F14	650 Hz	0 dBm for 40 msec
F5	1550 Hz	0 dBm for 40 msec	F15	550 Hz	0 dBm for 40 msec
F6	1450 Hz	0 dBm for 40 msec	F16	2350 Hz	0 dBm for 40 msec
F7	1350 Hz	0 dBm for 40 msec	F17	2450 Hz	0 dBm for 40 msec

Encode Formats:

DTMF (0-9, *, #, A, B, C)
 5-Tone (CCIR, DZVEI, DDZVEI, EEA, EIA, Eurosignal, MODAT, NATEL, ZVEI)
 2-Tone
 Pulse Tone (1500 Hz & 2805 Hz)

Decode Formats:

Motorola's MDC-1200 ANI and Emergency ANI

GENERAL INFORMATION

Midian's TRC-500 is a tone remote controller with Motorola MDC-1200 ANI and ENI display decoding with dialing capabilities in DTMF, 5-Tone, Pulse Tone and 2-Tone. The TRC uses EIA and Industry standards for monitor, guard, and F1-F16 function tones. Midian also adds F17 for additional function control when used with Midian's TTC-1. The built-in display shows the frequency/function selection, real-time clock and the decoded ANI/ENI with Alias.

The TRC comes standard with an internal microphone and speaker. A gooseneck microphone (TRC Option A) or handset and cradle (TRC Option C) are also available. The standard configuration is for a 2-wire and single line system. A 4-wire option (TRC Option F) or a Line 2 option (TRC Option E) is available for these types of systems.

Midian's TRC can be used with Midian's TTC-1, tone remote adaptor, or another manufacturer's tone remote adaptor that uses EIA and industry standard F1-F16 function tones.

Be certain to follow standard anti-static procedures when handling any of Midian's products.

Getting Started:

The TRC has a number of adjustment potentiometers and configuration jumpers. These have been adjusted and configured at the factory for a typical installation. However, audio levels should be verified and adjusted (if necessary) at the time of installation. Also, the configuration jumpers should be inspected prior to installation to verify that they are in the right configuration. Jumper descriptions appear in the jumper settings section with a quick reference table. **NOTE:** The Zener Diode D-605 is installed to reduce the input voltage to regulators U601 and U602. D-605 is operating within specifications however when the TRC is open for adjustment, care should be used to avoid touching the diode as it can be hot to the touch.

Line Interface

The line interface connector PL1 is a 10-pin RJ-45 style connector in the center of the back panel. A standard 4-pin RJ-11 cable will plug into the RJ-45 and connect to the center 4-pins that are needed for 2-wire or 4-wire interfaces. The remaining 6 pins are for use with a telemetry radio or microwave E&M options and for future interoperability options.

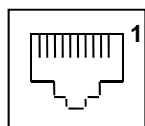

Diagram 3.1

2-Wire & Line 1 Operation: For a single line, 2-wire installation, simply connect pins 5 and 6 (red and green) to the dedicated line. This is the standard configuration for the TRC. See table 3.1.

Table 3.1

Pin	Color	2-Wire
PL1-4	Black	Not Used
PL1-5	Red	Line 1
PL1-6	Green	Line 1
PL1-7	Yellow	Not Used

2-Wire with Line 1 & 2 Operation: For a 2-line, 2-wire installation connect pins 5 and 6 (red and green) for line 1 and pins 4 and 7 (black and yellow) for line 2. For this feature TRC Option E must be installed in the TRC. Remove JP202 and JP203 for proper operation. See table 3.2. Please note that the 4-Wire Option (TRC Option F) is not available in Line 2 operation.

Table 3.2

Pin	Color	2-Wire
PL1-4	Black	Line 2
PL1-5	Red	Line 1
PL1-6	Green	Line 1
PL1-7	Yellow	Line 2

4-Wire & Line 1 Operation: For a single line 4-wire installation, connect pins 4 and 7 (black and yellow) for receive audio and pins 5 and 6 (red and green) for transmit audio. For this feature TRC Option F must be installed in the TRC. JP204 should be moved to the 3-4 position. See table 3.3. Please note that the Line 2/Supervisor Option (TRC Option E) is not available in 4-wire operation.

Table 3.3

Pin	Color	4-Wire
PL1-4	Black	RX
PL1-5	Red	TX
PL1-6	Green	TX
PL1-7	Yellow	RX

Parallel Remote Operation: When multiple remotes are connected to a single dedicate phone line JP304 must be installed in the unit furthest from the phone line connection. All remaining units must have JP304 removed.

Diagram 3.2 – Parallel Remote Wiring

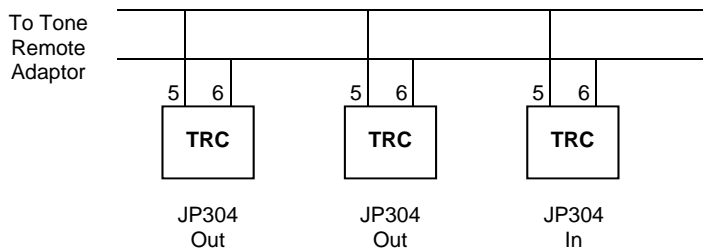

Supervisor Operation: When using the supervisor option (TRC Option E), the supervisor TRC is connected to the line via pins 2 and 3. The remaining TRC's pins 5 and 6 are connected in parallel to the supervisor's TRC pins 4 and 7. To enable these remotes, the supervisor relay must be engaged by pressing the * and # keys simultaneously.

Diagram 3.3 – Supervisor Wiring

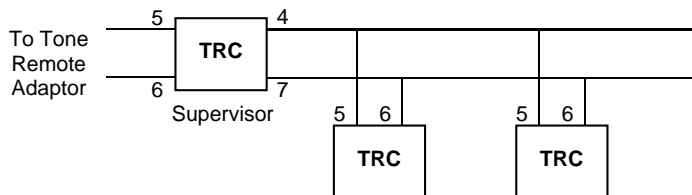

Telemetry Radio: Rather than connecting the TRC to a dedicated line to communicate with the tone remote adaptor, telemetry radios can be used for communication. If connecting to a telemetry radio connect PL1 as follows to the radio:

PL1-3: PTT Output: Connect to the PTT of the radio. Jumpers JP210 1-2 and JP208 1-2 should be installed.

PL1-6: TX Audio Output: Connect to the mic-hi input of the radio. Install JP205 2-3.

PL1-7: RX Audio Input: Connect to a point in the radio providing flat receive audio. Install JP11 1-2 & remove JP204.

PL1-9: Battery: 15 volts through a 100 Ohm current limiting resistor (R216).

PL1-10: Ground: Connect to the ground of the radio.

Microwave: Connect the 4-wire audio to the TX and RX sides of the microwave. If the M lead is desired install JP208 1-2 and JP10 1-2. Connect the microwave's M lead to PL1 Pin 3 for an open collector to ground. If using an external relay to control the microwave's M lead you may use Q205 to provide 12 volts and install JP207 1-2 and JP208 2-3.

PL1-8: External Speaker or PA System

HARDWARE ALIGNMENT

The following procedures assume a good quality dedicated line is being used and the tone remote adaptor is already installed. The alignments are preset at the factory and should not need to be adjusted during installation. However, if an adjustment is needed, please follow the procedures below.

RX Input Line Level Adjustment:

1. With the dedicated line connected to the TRC, connect a line level meter to the red and green (or yellow & black with the 4-wire option) in bridging mode. If testing on a bench with no tone remote adaptor available use termination mode on the line level meter.
2. With the line level meter generating Low-Level Guard Tone at -20 dBm, monitor TP304 with an oscilloscope.
3. Adjust RP306, so that 200 mV p-p is seen at TP304 or 165 mV p-p is seen at TP301. If paralleling multiple remotes, this alignment should be done with all remotes attached.

TX Output Line Level Adjustment:

1. With the dedicated line connected to the TRC, connect a line level meter to the red and green in bridging mode. If testing on a bench with no tone remote adaptor available use termination mode on the line level meter.
2. Set RP201 to 90%.
3. Push and hold the SEND key on the TRC to generate the Low-Level Guard Tone.
4. Adjust RP202 so that the line level meter shows the Low-Level Guard Tone at -20 dBm. If paralleling multiple remotes, this alignment should be done with all remotes attached.

RX Notch Filter Alignment:

1. Generate the 2175 Hz Low-Level Guard Tone to the TRC.
2. Turn RP303 fully clockwise.
3. Monitor TP303 with a Sinadder. The sensitivity of the Sinadder should be adjusted to hear the tone.
4. Adjust RP302 until the tone is at it's most diminished point.
5. Adjust RP303 until the tone fully diminishes.
6. Repeat steps 4 and 5 until no tone remains.

TX Notch Filter Alignment:

1. Unplug the internal microphone from the TRC, install JP101 1-2 and turn RP102 fully clockwise.
2. Push and hold the SEND key on the TRC to generate the 2175 Hz Low-Level Guard Tone.
3. Monitor TP103 with a Sinadder. The sensitivity of the Sinadder should be adjusted to hear the tone.
4. Adjust RP103 until the tone is at it's most diminished point.
5. Adjust RP102 until the tone fully diminishes.
6. Repeat steps 4 and 5 until no tone remains.
7. After aligning the TX notch filter, remove JP101 and plug back in the internal or gooseneck microphone.

Handset Ear Level (TRC Option C Only):

1. With a field radio talking on channel to the TRC, adjust RP304 to a comfortable level.

Motorola MDC-1200 Decode Level Alignment:

1. Transmit a 1500 Hz test tone over the air at approximately 2/3 full system deviation (3.3 kHz wideband, 1.7 kHz narrowband).
2. Monitor TP501 with an oscilloscope and adjust RP501 for maximum amplitude, so that 700 mV p-p (250 mV RMS) is seen at TP501.

JUMPER SETTINGS

The following table shows the default jumper settings and their function:

Jumper Number	Default Position	Description
JP101	Out	Install during TX Notch Filter Alignment only
JP201	Out	Sidetone for dialing (4-wire option only)
JP202	In	Removed when TRC Option E is installed (Line 2/Supervisor)
JP203	In	Removed when TRC Option E is installed (Line 2/Supervisor)
JP204	1-2 In – 3-4 Out	2-wire (1-2 In 3-4 Out) or 4-wire option (1-2 Out 3-4 In)
JP205	1-2 In – 2-3 Out	Balanced (1-2 In 2-3 Out)/Unbalanced (1-2 Out 2-3 In) Audio Selection for use with a telemetry radio instead of a dedicated line.
JP206	Out	Power with current limit.
JP207	Out	Activates Q205 to provide 14 V to external M lead relay.
JP208	Out	If JP208 1-2 is installed with JP210 1-2, provides an open-collector to ground on PL1-3 to PTT a telemetry radio or ground a relay for an M lead.
JP209	In	Always installed unless directed otherwise by Midian.
JP210	1-2 Out – 2-3 Out	Install JP210 1-2 with JP208 1-2 to PTT a telemetry radio.
JP301	1-2 In – 2-3 Out	Future Use
JP302	Out	Handset Audio Feedback. Install only with the TRC Option C if dial tones and voice in the ear piece are desired.
JP303	Out	TX Audio Loading. If less TX audio is needed, install this jumper.
JP304	In	2-Wire RX Audio Termination. If more RX audio is needed, remove this jumper. This should only be needed if paralleling remotes.
JP305	Out	4-wire option only. RX Audio Loading. If less RX audio is needed, install this jumper.
JP306	Out	4-wire option only. RX Audio Termination. If more RX audio is needed, remove this jumper. This should only be needed if paralleling remotes.
JP307	1-2 Out – 2-3 In	With 2-3 installed the volume control switch is the main source of controlling the handset ear piece audio level. With 1-2 installed and 2-3 removed, the volume control switch does not affect the handset ear piece audio level and RP304 is the only source of control.
JP308	Out	Low impedance audio for external speaker or PA System.
JP309	In	Leave In: In for hard mute and out for soft mute
JP401	Out	Factory Use Only
JP409	Out	Factory Use Only

CONTROLS & INDICATORS

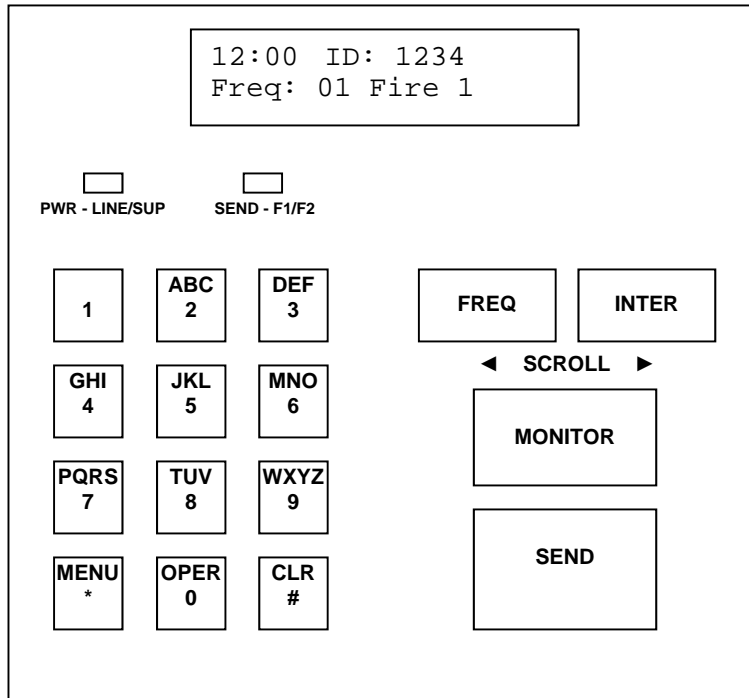

Power/Volume Switch: On the right side of the TRC, there is a switch which acts as the power and volume switch. The switch is in the power off position when turned fully clockwise past the click. Turning the switch counter-clockwise past the click turns the power on to the volume control. At this point the volume is in the low position. Turning the switch further counter-clockwise increases the volume.

LCD: The 2-line LCD displays the time and unit ID on the first line and the frequency selection and frequency alias on the second. When a dialing sequence is performed the second line is cleared and the dialing sequence is displayed. Channel changes are also shown between parallel remotes.

LED 1 (PWR - LINE/SUP): This LED is a bi-color LED. The LED will glow red when the power is on to the TRC. It glows orange when Line 2/Supervisor mode is active.

LED 2 (SEND - F1/F2): This LED is a tri-color LED. The LED will glow red during transmit of Freq 1 and orange during transmit of Freq 2. It glows green when Guard Tone is detected from a parallel tone remote.

FREQ: The FREQ button acts as the frequency select and the function select key. Pressing this key followed by 0-17 will select the associated frequency or function. When using the TRC with Midian's TTC-1 tone remote adaptor both frequency and function tones are available. When using the TRC with another manufacturer's tone remote adaptor the frequency tones are selectable.

INTER: Pressing the INTER key will allow intercom communications between several connected tone remotes without transmitting over the radio. When the INTER key is pressed and held, the audio is routed on the line without the Guard Tone activating the transmitter. Other tone remotes on the same line will hear the audio automatically. No cross mute is available in intercom mode since there is no Guard Tone present.

MONITOR: Pressing the MONITOR key will allow the user to monitor the channel before pressing the SEND key to make a call. If a conversation is heard then another co-channel user presently "owns" the channel and should not be interrupted.

SEND: Pressing SEND will transmit the high-level guard tone for 120 msec, followed by the frequency tone for 40 msec, followed by the low-level guard tone that keys the radio with the voice and dialing riding over the low-level continuous tone.

0-9 Keys: Used in conjunction with the **FREQ** key these number keys can be used to select the frequency/function tone.

***/MENU:** The MENU key takes the user into call mode and setup mode.

#/CLR: When CLR is pressed, any keyboard entries in the buffer will be cleared.

The TRC has 4 operating modes:

Control Mode: This is the normal operating mode. It allows for remote control of a base station equipped with a tone remote adaptor such as Midian's TTC-1.

ANI Review Mode: This mode is for viewing the last 10 ANI's stored in the ANI log.

Call Mode: This mode is for encoding DTMF, 5-Tone, 2-Tone or Pulse Tone.

Menu Mode: This mode is for configuring the TRC programmable features.

Control Mode:

In Control Mode the LCD display the time and ID of the last ANI received on the first line. On the second line the selected frequency is displayed along with the programmed alias for that channel. If using with other Midian TRC's (revision G and higher), the paralleled remotes will also show the channel change on the display. **Note:** Upon decoding of an ANI the LCD will toggle briefly between Control Mode and ANI Review Mode.

```
12:00 ID: 1234
Freq: 01 Fire 1
```

Frequency versus Function: The F1-F17 tones are referred to, industry wide, as Function Tones, but are used as frequency selector tones to control the base station radio channel selection. Midian, with it's TTC-1 tone remote adaptor can use the Function Tones for either frequency selection or for controlling a function for remote monitoring and control. These functions can be used for turning on/off a scrambler in the TTC-1, controlling voice prompts from the TTC-1, or providing outputs from the TTC-1 to the TTC Option A (wild card module) for remotely controlling equipment. If using the TRC with the LCD Option (TRC Option I) the TRC will display the Frequency and the Function. For example, Frequency 1 can be selected while controlling Function 5 and the display will show "Freq: 01 Func: 05". A frequency and function should not share the same Function Tone. For example, if only channel 1 and 2 at the base station need to be controlled (F1-F2), this leaves F3-F17 for use as function control. If 16 channels need to be controlled at the base station (F1-F16), this leaves F17 for use as function control.

Frequency Selection: To change the channel of the radio (F1 up to F16), press the **FREQ** button followed by a single digit number for F1-F9 or a double digit number for F01-F16. When the Function Tone is selected, the TRC sends the High-Level Guard Tone followed by the selected Function Tone to the tone remote adaptor to change the channel of the radio. If using with other Midian TRC's (revision G and higher), the paralleled remotes will also show the channel change on the display.

Function Selection: To control a function press the **FREQ** button followed by a single digit number for F1-F9 or a double digit number for F10-F16. When the Function Tone is selected, the TRC sends the High-Level Guard Tone followed by the selected Function Tone to the TTC-1 to command the function control. **Note:** The selection of a function does not cancel any frequency selection. If the TRC is on Frequency 1 and Function 5 is selected, the tone remote adaptor will remain on Frequency 1.

Transmitting: After selecting the desired Function Tone for frequency selection, pressing and holding the **SEND** key will generate the High-Level Guard Tone followed by the continuous Low-Level Guard Tone. The user speaks into the microphone of the TRC and the voice goes out over the Low-Level Guard Tone.

Monitor: Prior to transmitting or dialing, the user should Monitor the channel to see if there is activity on the channel. If there is activity, the user should wait until the channel is clear. Pressing the MONITOR button sends the High-Level Guard Tone followed by the Monitor Function Tone to the tone remote adaptor giving it a command to open the squelch of the radio. Depending on the tone remote adaptor this can be momentary or latched. If momentary, the tone remote adaptor will close the squelch of the radio after a set amount of time. If latched, the squelch will remain open until the tone remote adaptor receives a second Monitor command from the TRC.

Receiving: When a field radio keys up, the tone remote adaptor passes the voice down the line to the TRC. The voice will then be passed through to the internal speaker of the TRC.

Line 2/Supervisor Capability (* + #): If the TRC is ordered with TRC Option E, then the TRC is equipped with the Line 2/Supervisor Capability. Line 2 is used for toggling between 2 different base station radios and Supervisor is used to shut down any paralleled remotes. Pressing the * and # keys simultaneously activates the Supervisor or the Line 2 mode depending on the options installed in the unit. Pressing the keys again deactivates the Supervisor or the Line 2 mode. When activated LED 1 changes from red to orange.

Memory Dialing: The TRC supports up to 9 memory dials (1-9). Press and release the * key, followed by the desired 1-9 number key for 1 second.

Last Number Redial: The TRC can recall the last sequence dialed by pressing and releasing the * key followed by the SEND key.

ANI Review Mode:

Pressing FREQ and INTER at the same time while in Control Mode will change the mode to ANI Review Mode. In this mode, the ANI is shown first on the first line followed by the timestamp. The second line shows the alias of the decoded ANI, if programmed.

1234	12:00	
< John Smith		>

When ANI Review Mode is brought up the last incoming ANI is shown first. Pressing the FREQ scrolls the log to the next most recent ANI in the log. Pressing INTER scrolls the log to the newer entries in the ANI log. When there are additional older ANI's to be displayed then the < icon is shown to the left. When there are additional newer ANI's to be displayed then the > icon is shown to the right.

If the status feature is enabled and a status is received with the ANI, then the ANI will alternate every 2 seconds between the ANI and the status message.

To return to the Control Mode press FREQ and INTER simultaneously or press the CLR # key.

Call Mode:

To enter call mode press the MENU key and CALL will be displayed on the LCD. Press the SEND key to select the CALL function.

Direct Dialing: Once in the call mode as above, simply press the numeric keys of the desired dialing sequence and press SEND.

Database Dialing: Once in the call mode as above, simply press the INTER key to scroll right through the database until the desired ID is found. Once found, press the SEND key. If while scrolling the desired ID is passed by, press the FREQ key to scroll left.

Speed Dialing: Speed dialing can be done in the Control Mode or ANI Review Mode. The speed dials (or memory dials) are set up in the Menu Mode of this manual. The TRC can have 9 speed dial memory locations set up in memory, which are associated with the 1-9 keys. Press and release the * key and the press and hold the desired 1-9 key for 1 second and the unit will automatically dial the associated speed dial.

Menu Mode:

For details on the Menu Mode please reference the Product Programming section.

PRODUCT PROGRAMMING

The following is a map of the menu system in the TRC. Menu shortcut numbers are shown to the right of the menu item to which it applies.

MAIN MENU

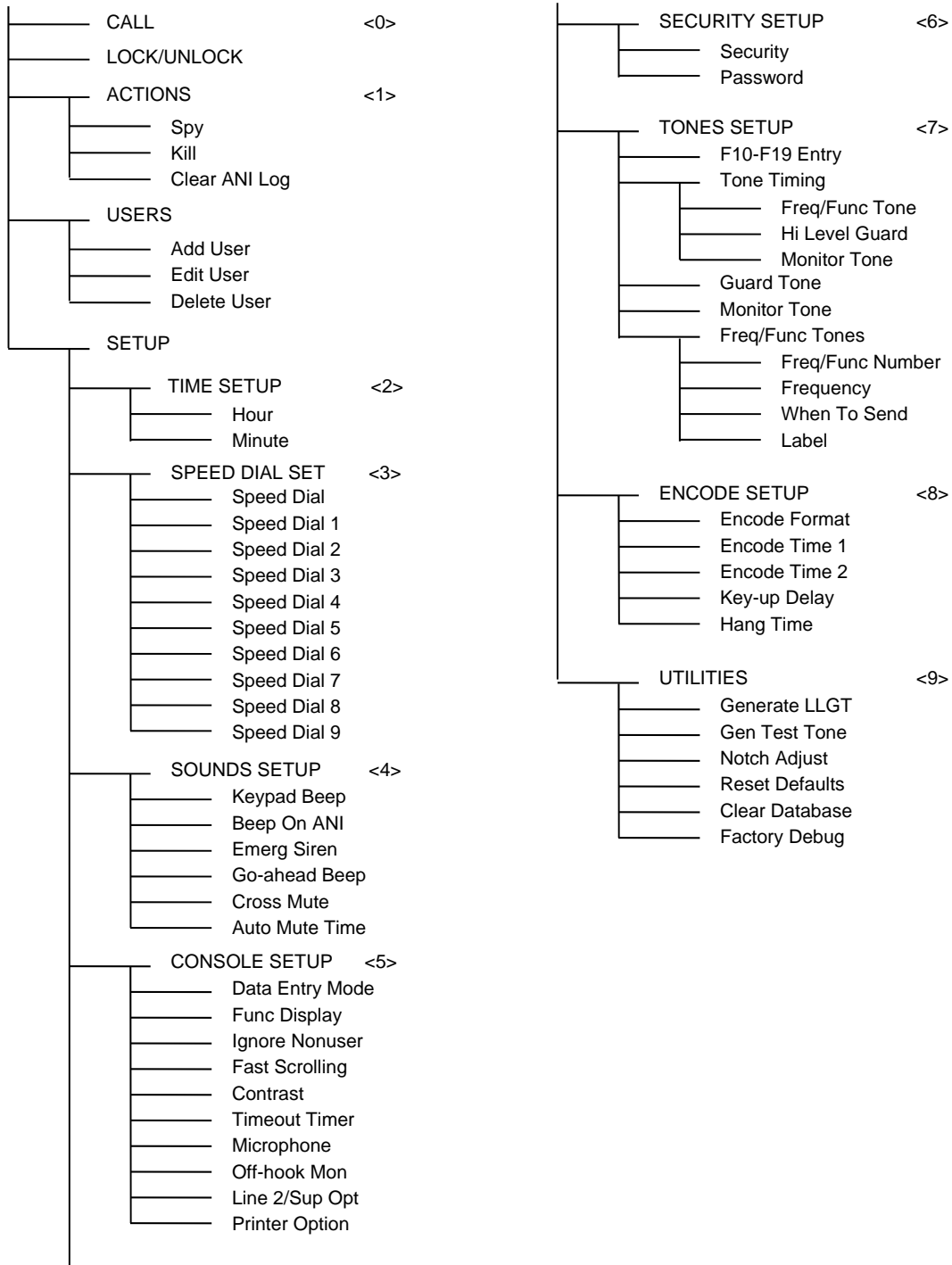

Navigating the Menus

Press the key MENU key while in Control or ANI Review Mode to place the unit into Menu Mode. Upon entry to Menu Mode, you will be in the Main Menu. The top line of the display indicates this. The bottom line displays an item available for selection. When MENU is first selected the first available selection is for the CALL command.

The FREQ and INTER keys become scroll keys just as they do in ANI Review Mode. The scroll right symbol on the right side of the display indicates that additional items are available. Press the INTER (SCROLL >) key to view the next available item. The scroll left symbol will then appear, indicating that the FREQ (SCROLL <) key may be used to go back to the previous item.

To select the displayed item, press the SEND key (the SEND key is the ENTER key in menu mode). Upon selection, the name of the item will appear on the top line of the display. The bottom line will present additional items for selection. Press the CLR key to return to the previous selection.

When in menu mode, the number keys become menu shortcut keys which allow you to quickly jump to certain menus without scrolling. For example, pressing MENU followed by a <5> jumps directly to the Console Setup menu. One exception to this is the 0 key, which jumps directly to the call mode without having to press MENU. The other shortcut keys require the MENU key be pressed first if not already in Menu Mode.

Numeric VS. Alphanumeric Data

There are two different data entry modes available on the TRC. Numeric entry is the default mode when calling a unit. As numbers are entered, they appear on the bottom-left of the display. Pressing the MENU key while in numeric entry mode changes the mode to Alphanumeric. In alphanumeric mode, you may type in letters and numbers as shown in the table below. This allows you to type the name of a user in the database without having to scroll through the names. Alphanumeric data appears on the bottom line of the display as it is entered. You may make alphanumeric call entry the default mode by changing the Data Entry Mode setting in the CONSOLE SETUP menu.

Entering Alphanumeric Data

Before you can add names to the database, you must learn the scheme for entering alphabetic characters using the numeric keypad. All of the letters of the alphabet appear above the numbers on the keypad. For example, the letters 'A' 'B' and 'C' appear on the <2> key.

Alphabetic characters are entered by pressing 2 digits. The first digit is the key with the desired letter appearing on it. The 2nd digit is the position of the letter on that key. For example, the code for the letter 'C' is 23 since it is the 3rd letter on the <2> key. The letter 'T' is the 1st letter on the <8> key, so its code is 81.

To enter numeric characters in alphanumeric data entry mode, press the <0> key followed by the desired digit. Punctuation characters such as comma <,> and <-> do not appear on the keypad. Special codes have been assigned to allow entry of those characters. Please refer to the following chart.

Note: Alphanumeric mode cannot be used to enter user ID's (ANI's). In alphanumeric mode, numbers are treated the same as letters

A=21	I=43	Q=72	Y=93	7=07	- =15
B=22	J=51	R=73	Z=94	8=08	= =16
C=23	K=52	S=74	1=01	9=09	* =17
D=31	L=53	T=81	2=02	0=00	/ =18
E=32	M=61	U=82	3=03	, =11	# =19
F=33	N=62	V=83	4=04	. =12	space=10
G=41	O=63	W=91	5=05	_ =13	
H=42	P=71	X=92	6=06	+ =14	

Entering Special DTMF Digits: The TRC supports the following special DTMF 'digits' in numeric entry mode: *, #, A, B, and C (D is not supported). These are entered using 2-key sequences as follows:

* = * *	# = * #	A = * 1	B = * 2	C = * 3
---------	---------	---------	---------	---------

These special digits can only be entered when adding a User ID to the database. They cannot be dialed directly from the CALL menu. These special digits cannot be used unless DTMF is used as the encode format.

The following sections describe the various functions of the menu system. Shortcut keys are shown for those menu items that have shortcuts. Factory default settings are shown underlined.

CALL <0>

When the call command is selected you will be prompted to enter a user ID. You can either enter a unit ID or scroll right to enter into the database. The database will show the user ID, if you wish to display the user name press the MENU key to switch between the user ID and the user name. Once the desired user is found press SEND to call the unit.

LOCK/UNLOCK

Note: The Lock and Unlock menu options do not appear unless enabled in security setup. If enabled the password protects all options in the menu map after the call option. Enter the 4-digit password that was set up in the security setup to unlock the menu.

ACTIONS <1>

Spy command: Allows you to remotely key-up and listen to a unit equipped with one of Midian's UD-1/UED-1 series encoder/decoders. The code for spying on a unit must be in the user database to use this function. Type in the user ID or scroll to the desired ID or name in the database and press the SEND key.

Kill command: Allows you to remotely disable a unit equipped with Midian's UED-1 series encoder/decoder. The code for killing a unit must be in the user database to use this function. Type in the user ID or scroll to the desired ID or name in the database and press the SEND key.

Clear ANI Log command: Allows you to clear the ANI log without having to turn the unit off and back on.

USERS menu

Add User menu: Allows you to add a new user to the database. When ADD USER is selected, you will be prompted to fill in the information for that user such as User ID and User Name followed by a Kill ID and a Spy ID.

Delete User menu: Allows you to delete a user record from the database. When DELETE USER is selected, you will be able to select the user you wish to delete in the same manner as if placing a CALL. Use the scroll keys to find the user you wish to delete. Press SEND to delete the selected user. You will have to press SEND a second time to confirm. Press CLR to cancel.

EDIT USER menu: Allows you to change information about a user. Select the user you wish to edit in the same manner as if placing a CALL to that user. Use the scroll buttons to find the user you wish to edit. Press SEND to edit the information for the selected user. You will be prompted to fill out each field in turn. After entering the data for a field, press SEND to go on to the next field. To leave a field unchanged, simply press SEND without entering data. If not using the Spy or Kill features, just leave these fields blank and press SEND.

User ID: This numeric field contains the ANI assigned to the user's radio. This will be the number used when decoding the ANI. ID's are 4 digits in length. This is a required field.

Range: 0-4 digits
Default: blank

User Name: This alphanumeric field contains the name of the user associated with the user ID. A maximum of 14 characters may be used.

Range: 0-14 characters
Default: blank

Spy ID: Specify the code required to spy on this unit. Leave blank if not using this feature.

Range: 0-8 digits
Default: blank

Kill ID: Specify the code required to disable this unit. Leave blank if not using this feature.

Range: 0-8 digits
Default: blank

SETUP menu

TIME SETUP <2>

In order for the correct time to be displayed, the real-time clock must be set. Time is represented in 24-hour format and all four digits must be entered.

Range: 0000-2359
Default: 0000

SPEED DIAL SET <3>

Speed Dial feature: When in Control Mode or ANI Review mode, the number keys <1> through <9> may be turned into speed dial keys by enabling this feature.

OFF Speed dialing disabled.
ON Speed dialing enabled.

Speed Dial 1-9: To associate a unit to a speed dial number, it must be in the user database. For each speed dial entry, simply locate the user in the database in the same manner as if placing a call to a unit.

Range: 0-14 characters
Default: blank

SOUNDS SETUP <4>

Keypad Beep: Turning this option on causes a beep to be heard for each key press.

OFF Keypad beeps off
ON Keypad beeps on

Beep On ANI: Turning this option on will cause an alert beep to be heard every time a new ANI is received.

OFF Do not beep when ANI comes in.
ON Beep when ANI comes in.

Emerg Siren: This causes a siren sound to be heard when an emergency ANI is received. This requires turning on the Emerg Status option in the STATUS SETUP.

OFF Do not sound siren on emergency ANI.
ON Sound siren on all emergency ANI's.

Go-ahead Beep: When using the TRC as an encoder, it will take some time for the signaling to take place. The operator must wait for this time to elapse before speaking or he/she will not be heard. The go-ahead beep alerts the operator when the signaling is complete so they will know when it is okay to begin speaking.

OFF Disable go-ahead beep.
ON Enable go-ahead beep.

Cross Mute: If using more than one TRC in the same room, feedback (howling) may occur if one unit is transmitting while another is listening. Enabling Cross Mute prevents this from happening by muting the internal speaker whenever guard tone is detected.

OFF Cross Mute disabled.
ON Cross Mute enabled.

Auto Mute time: Specifies the amount of time after guard tone is detected that the internal speaker will be muted. This facilitates muting of the function tone and/or signaling tones generated by parallel remotes. All four digits must be entered. If 0000 is entered, the feature is disabled.

Range: 0000 to 9999 milliseconds
Default: 0000 milliseconds

CONSOLE SETUP menu <5>

Data Entry Mode: Determines if numeric entry or alphanumeric data entry is the default mode when placing a call. The mode of entry can also be toggled by pressing the MENU key during data entry. Enable alphanumeric mode only after entering names and numbers in the user database.

NUMERIC Start in numeric only mode.
ALPHA Start entry in alphanumeric mode.

Func Display: Turning on this option causes the last selected function to be displayed every 2 seconds on the bottom line of the display when in Control Mode. This option applies only when there is a distinction between frequency and function in your application.

OFF Disable function display.
ON Enable function display.

Ignore Nonuser: Turning on this option helps prevent the display of false decodes by ignoring ID's which do not appear in the user database.

OFF Display ID's not in database.
ON Ignore ID's not in database.

Fast Scrolling: Fast Scrolling allows for faster navigation through the menu system. When this setting is turned off, menu items will appear to scroll from side-to-side. This provides positive feedback in response to scrolling through menus and the ANI log. If this effect is desired, Fast Scrolling can be disabled.

OFF Scroll slowly to give side-to-side effect.
ON Scroll at fast speed.

Contrast : Allows the display contrast to be adjusted for best viewing.

LOW Low contrast setting.
HIGH High contrast setting.

Timeout Timer: Prevents the transmitter from being keyed indefinitely if the SEND key is stuck or unintentionally in the depressed position. The TRC will cease sending low-level guard tone and disable the line driver after the amount of time programmed by this setting. This timer also applies to the INTER key. If set to 00, the timeout timer feature will be disabled. Both digits must be entered.

Range: 00 to 99 seconds
Default: 00 seconds

Microphone: Selects which type of microphone is attached to the TRC. Be sure to set jumpers accordingly.

INT/GOOSENECK Internal or gooseneck style microphone.
HANDSET External handset.

Off-hook Mon: If enabled, the TRC will automatically transmit the Monitor Function sequence as per FCC requirements when the operator picks up an externally attached handset. For privately owned systems this option can be disabled. The External Handset Option must be enabled for this setting to be recognized.

OFF Do not transmit the monitor sequence when the handset goes off-hook.
ON Automatically transmit the monitor sequence when the handset goes off-hook.

Line 2/Sup Opt: If the line-2/supervisor relay is installed, this setting must be enabled for the feature to work.

OFF Line 2 or supervisor option disabled.
ON Line 2 or supervisor option enabled.

Printer Option: The TRC, if ordered with the printer cable option, can log the ANI traffic to a serial printer or computer. The printer must have a print buffer and a standard RS-232 port. It must be configured for 9600 baud, 8 data bits, 1 stop bit and no parity. In order to send data to the printer, this option must be on.

OFF Do not send data to printer.
ON Send data to printer.

SECURITY SETUP menu <6>

Security: Allows the security option to be turned on and off. If off, the Lock/Unlock menus will not appear.

OFF Disable security feature.
ON Enable security feature.

Password: Sets the password used to unlock the menu system when the security is enabled. Must be 4 numeric digits.

Range: 4 digits
Default: 0000

TONES SETUP menu <7>:

F10-F19 Entry: By default, the TRC will expect one digit to be pressed after the FREQ key is pressed. This however prevents the use of F10 – F19 function tones. If these tones are to be used, turn on this setting. This will cause the TRC to wait 2 seconds after FREQ <1> is pressed for the 2nd digit. If no 2nd digit is entered after 2 seconds (or SEND is pressed), F1 will be selected.

OFF Disable F10 – F19 entry.
ON Enable F10 – F19 entry.

Tone Timing: This menu allows the modification of the default timing of the frequency/function tones, the high level guard tone, and the monitor tone. Any of these tone types may be disabled by setting the timing to 0000. All four digits must be entered.

Freq/Func Tone

Range: 0000 to 9999 milliseconds
Default: 0040 milliseconds

Hi Level Guard

Range: 0000 to 9999 milliseconds
Default: 0120 milliseconds

Monitor Tone

Range: 0000 to 9999 milliseconds
Default: 0040 milliseconds

Guard Tone: This changes the guard tone frequency. All four digits must be entered.

Range: 2100 to 3100 Hz
Default: 2175

Monitor Tone: This changes the guard tone frequency. All four digits must be entered.

Range: 0550 to 3100 Hz
Default: 2050

FreqFunc Tones: This allows editing the attributes for each of the frequency/function tones F1 – F19. There are three attributes of each tone that you can change. The defaults for each tone are shown in the table below.

Freq/Func Number: Select the Freq/Func tone number whose attributes you wish to edit using the SCROLL buttons. When the desired tone number is displayed, press SEND. You will then be prompted to modify or accept each of the three attributes associated with that tone. To leave an attribute unchanged, simply press SEND to accept the value. All three attributes must be modified or accepted for the changes to take effect.

Frequency setting: This allows you to pick a custom frequency for each tone. Note that all four digits must be entered.

Range: 0550 to 3100 Hz
Default: see below

When to Send setting: Select when the frequency/function tone is sent. The options are as follows:

AFTER SEND: The tone will be sent after high level guard tone every time the SEND key is pressed and ONLY after the SEND key is pressed. Therefore this setting is applicable only when the tone is used only for TX frequency control.

AFTER FREQ: The selected tone will be sent (preceded by high level guard tone) immediately after being selected by pressing FREQ followed by the tone number. The tone to be sent after pressing SEND will not be changed. This is the setting to select when the tone is used for function control only. It will be classified as a function when function display is turned on. This could also be used for RX frequency control (if different from TX).

BOTH: The selected tone will be sent (preceded by high level guard tone) immediately after being selected by pressing FREQ followed by the tone number. This tone will also be sent the next time SEND is pressed. This is the setting to select when the tone is used for both RX and TX frequency control (most common). A tone with this setting will be treated as a frequency as opposed to a function.

Label setting: Allows you to label the frequency/function tone to clarify how it is being used. The programmed label will appear when in Control Mode.

Range: 0-8 characters
 Default: see below

Freq/Func Defaults: The following are the default attributes for the frequency/function tones when shipped from the factory:

Tone	Frequency	When to Send	Label
F1	1950	BOTH	CHAN 1
F2	1850	BOTH	CHAN 2
F3	1750	BOTH	CHAN 3
F4	1650	BOTH	CHAN 4
F5	1550	AFTER FREQ	FUNC 5
F6	1450	AFTER FREQ	FUNC 6
F7	1350	AFTER FREQ	FUNC 7
F8	1250	AFTER FREQ	FUNC 8
F9	1150	AFTER FREQ	FUNC 9
F10	1050	AFTER FREQ	FUNC 10
F11	950	AFTER FREQ	FUNC 11
F12	850	AFTER FREQ	FUNC 12
F13	750	AFTER FREQ	FUNC 13
F14	650	AFTER FREQ	FUNC 14
F15	550	AFTER FREQ	FUNC 15
F16	2350	AFTER FREQ	FUNC 16
F17	2450	AFTER FREQ	FUNC 17
F18	2550	AFTER FREQ	FUNC 18
F19	2650	AFTER FREQ	FUNC 19

Note: F16 through F19 do not have standardized tone definitions.

ENCODE SETUP menu <8>

Encode Format: The tone-signaling format used to encode outgoing calls. Please note that a number of the formats employ tones that should not be used unless a non-standard guard tone is used by the system. Please refer to the Tone Signaling section for signaling format compatibility.

Encode Time 1: When using 2-tone or 5-tone, this sets the length of time for the first tone of the sequence. When using DTMF, this is the tone ON time for DTMF tones.

Range: 0005 to 9999 milliseconds
Default: 0050 milliseconds

Encode Time 2: When using 2-tone or 5-tone, this sets the duration of each of the remaining tones of the sequence. When using DTMF, this is the tone OFF time (between digits).

Range: 0005 to 9999 milliseconds
Default: 0050 milliseconds

Key-Up Delay: This is the amount of time the TRC will wait after sending guard and function tone before sending the encode sequence over the air. This time allows for delays introduced by repeaters and decoding of squelch control signals such as CTCSS.

Range: 0005 to 9999 milliseconds
Default: 0100 milliseconds

Hang Time: Low-level guard tone will continue to be sent for this much time after encoding is completed. This gives the operator time to say a brief voice message, or to press SEND before the guard tone drops. Hang time does not apply when unless making a encoding.

Range: 0000 to 9990 milliseconds
Default: 0000 milliseconds

UTILITIES menu <9>

Generate LLGT: Causes the TRC to generate low-level guard tone continuously until told to quit. This utility may be also be used to adjust the TX audio level. Press CLR to stop tone generation when done.

Gen Test Tone: Causes the TRC to generate high level guard tone followed by a function tone. After that, a 1007 Hz test tone along with low-level guard tone will be generated for 10 seconds. This is useful for the measurement of signaling modulation.

Notch Adjust: Causes the TRC to generate a test tone at the guard tone frequency continuously until told to quit. The speaker is enabled while generating so that the RX notch filter may be adjusted. This utility may be also be used to adjust the TX notch filter. Press CLR to stop tone generation when done.

Reset Defaults: This will reset all the parameters listed above to the factory default settings. The contents of the user database will not be affected.

Clear Database: This will clear the user database of all ID's and User Names. The contents of the other parameters listed above will not be affected.

Factory Debug: This is used by the factory for product testing. Select this function only if directed to do so by Midian Technical Support.

TONE SIGNALING FORMATS

Tone Encoding Tables

Entering a user ID number, often called a CAP code, is straightforward for most of the encoding formats supported by the TRC. For example, when encoding DTMF or 5-tone, the digits 0-9 are simply typed in directly. Some formats do not allow for this straightforward approach. These are Plectron, Quick Call I, and Avcall. This section explains how to enter a code in these formats.

Plectron Encoding: To encode Plectron, four digits must be used. The first two digits represent the 1st tone, and the 2nd two digits represent the 2nd tone. Simply locate the code associated with each tone from the table. For example, the tone sequence 454.6 + 2688 would be entered as 1253.

Plectron Tones																	
01	282.2	08	382.2	15	517.7	22	701	29	950	36	1287	43	1743	50	2361	57	3197
02	294.7	09	399.2	16	540.7	23	732	30	992	37	1344	44	1820	51	2465	58	3339
03	307.8	10	416.9	17	564.6	24	765	31	1036	38	1403	45	1901	52	2574	59	3487
04	321.4	11	435.3	18	589.7	25	799	32	1082	39	1465	46	1985	53	2688		
05	335.6	12	454.6	19	615.8	26	834	33	1130	40	1530	47	2073	54	2808		
06	350.5	13	474.8	20	643	27	871	34	1180	41	1598	48	2165	55	2932		
07	366.0	14	495.8	21	672	28	910	35	1232	42	1669	49	2260	56	3062		

Avcall & Motorola Quick Call 1 Encoding: Avcall and Quick Call 1 are dual-tone formats, which means a pair of tones are sent simultaneously. Two tone-pairs are sent, meaning that four tones in total must be selected. Like Plectron, above, two digits are entered for each tone. Locate the desired tone in the table to find its corresponding code. A total of 8 digits must be entered. For example, the tone sequence 645.7 & 312.6 + 881.0 & 1479.1 would be entered as 07001015.

Avcall & Motorola Quick Call 1 Tones															
00	312.6	07	645.7	14	1333.5	21	668.3	28	412.1	35	851.1	42	473.2	49	346.7
01	346.7	08	716.1	15	1479.1	22	741.3	29	457.1	36	944.1	43	524.8	50	977.2
02	384.6	09	794.3	16	398.1	23	822.2	30	507.0	37	371.5	44	582.1	51	1084.0
03	426.6	10	881.0	17	441.6	24	912.0	31	562.3	38	1047.1	45	645.7		
04	473.2	11	977.2	18	489.8	25	358.9	32	623.7	39	1161.4	46	716.7		
05	524.8	12	1083.9	19	543.3	26	1011.6	33	691.8	40	384.6	47	794.3		
06	582.1	13	1202.3	20	602.6	27	1122.1	34	767.4	41	426.6	48	881.0		

Signaling Format Compatibility

In tone remote systems, the industry standard 2175 guard tone is filtered out by the tone remote adapter at the base station so that it is not heard over the air. This filter can affect signaling tones close to 2175 Hz. Tones within +/-70 Hz could be attenuated to a level such that they cannot be decoded by receiving equipment. There are several ways to deal with this issue:

1. Choose a format that will not be affected.
2. Do not use the affected tone(s).
3. Change the guard tone.

The last solution involves re-tuning the notch filters on the TRC. This can be done at the factory upon request (recommended). It also requires that the guard tone and notch filters on the tone remote adapter be changed as well. While Midian's products allow for this, not all do. Please note that this issue often applies to decoding as well. Many tone remote adapters notch 2175 out of the receive audio as well. This possibility should be investigated if decode problems are experienced. The following sections address the formats and tones that are likely to be affected.

ZVEI: All ZVEI formats use 2200 Hz for either the '0' or the '9' tone. This is only 25 Hz away from the standard guard tone frequency of 2175. The best solution to this problem is to simply not use the '0' tone when encoding DZVEI and not use the '9' tone when encoding ZVEI or DDZVEI formats. Alternatively, the guard tone could be changed to another frequency. If this is done, it should be at least 150 Hz away from the nearest frequency used by the format. 2970 Hz is a common choice.

CCIR and EEA: CCIR and EEA both use the tone 2110 Hz as the 'repeat' tone. This tone indicates that the current digit is the same number as the last digit. The best solution to this problem is to simply not use codes that have repeating digits. That is to say, do not use a code where a digit appears next to itself in the code such as '12334' which has two 3's in a row. Another solution is to change the guard tone. If this is done, it should be at least 150 Hz away from the nearest frequency used by the format. 2970 Hz is a common choice.

Other Affected Formats: REACH two-tone, tone group A, uses 2274, 2196, and 2121 Hz to represent the digits 6, 7, and 8. Do not use tone group A if using this format. PLECTRON tones 2260 and 2164 should not be used.

Formats Not Affected: The following formats do not use tones between 2105 and 2245 and therefore should be unaffected by the guard tone filter: AVCALL, DTMF, EIA, EUROSIGNAL, GE, MODAT, NATEL, QUICK CALL I, and QUICK CALL II.

SYSTEM ERROR MESSAGES

DATABASE EMPTY

Reason: An attempt was made to edit or delete a user when the database was empty.

Solution: These functions do not apply when the database is empty.

DATABASE FULL

Reason: An attempt was made to add a user to the database and there is no more room. The maximum number of user aliases of 128 cannot be exceeded.

Solution: Remove any old user names that are no longer in service. If this is not possible, contact Midian to learn about our Computer Aided Dispatch (CAD) fleet management systems which can handle many more users.

DATABASE ERROR

Reason: One or more entries in the user database has been corrupted. This can happen if power is lost at the exact time the database is being updated. Any corrupted records will be blanked-out and must be re-entered.

Solution: Cycle power to the unit. This should clear the error. If the error message continues to come up, contact Midian technical support.

DUPLICATE ID

Reason: An attempt was made to add a user ID to the database which is already in the database. Each user ID in the database must be unique.

Solution: Choose a unique user ID for each user. If it is necessary to edit the user record, use the edit menu.

EE CHKSUM ERR

Reason: The configuration settings stored in EEPROM have been corrupted. This can happen if power is lost at the exact time a parameter is being updated. All configuration settings will be set back to defaults. The user database should not be affected.

Solution: Cycle power to the unit. This should clear the error. If the error message continues to come up, contact Midian technical support.

EE WRITE FAIL

Reason: The EEPROM chip or connections to it have failed.

Solution: Contact Midian for instructions on getting the unit repaired.

FIELD IS BLANK

Reason: An attempt was made to place a call, but the user ID or name was blank. An attempt was made to spy or kill and the respective field in the database is blank.

Solution: When placing a call, be sure an ID number or user name is displayed before pressing SEND. The spy and kill functions require there be an entry in the respective field of the user database.

COPRO TIMEOUT

Reason: This message indicates that the coprocessor is not responding to commands from the main processor. Generally, this message should never be seen.

Solution: If this message is displayed, press the CLR key several times, three seconds apart, until the unit returns to normal. If it does not, try turning the power off and back on again. If this message continues to be displayed, or is displayed frequently, contact Midian technical support.

NOT FOUND

Reason: There is no entry in the user database that matches the data entered.

Solution: When selecting a user to call, the name or the ID can be entered in whole or in part. When entering a partial name or ID, press the right SCROLL button to search the database for the first partial match. Press SEND only if the whole ID or name has been entered. There may be no entry in the database that matches in whole or in part. In that case, the user must be added to the database.

SPEED DIAL EMPTY

Reason: You have pressed a speed dial number, but there is no user associated with it. The user may have been deleted, or no association was ever made.

Solution: Go to speed dial setup and associate a user in the database to the speed dial number.

Initial Power-up: Upon power-up the TRC defaults to Frequency 1 when the [SEND] button is pressed.

Analog Circuit

RX Audio Input Path: RX audio from a tone remote adaptor at the remote site travels down the phone line to the RJ-11 line interface connector PL-1. Line 1 uses the standard red/green Telco ring tip on positions 5 and 6 of the RJ-11 cable or pins 5 and 6 of the RJ-45 10-pin connector. This signal is fed into a transient absorber across the line, then through an auto-resettable polyswitch fuse to another set of transorbs that can shunt a signal to ground if the ground lead is tied to Earth. There are then 2 capacitors across the line, which also go to Earth to remove RF. The audio signal is then fed into transformer T201 through jumpers JP202 and JP203 or Line 2 relay K201. From the bottom winding of T201 audio is fed to jumper JP204 contacts 1 and 2 or contacts 2 and 3 if using T202 in a 4-wire duplex configuration. From JP204 audio is fed into the RX Input Gain Pot RP-306 where the output level of the RX line amp U302 is typically set to 200 mV p-p with -20 dbm from a Line Test Set tone generator.

There is a disable transistor Q303 that can mute the incoming audio under microprocessor control. Coming out of the RX line amp the audio is passed to the compression circuit U102B. The audio output of the compressor is also about 165 mV p-p and will change no more than 3 db over a 30-35 db input change. The audio then goes into the RX Bandpass amplifier U301D and the output of this Bandpass is fed into the Guard Tone detector which turns on the busy light and depending on how the unit is programmed can activate the crossmute function when another unit in the same room is transmitting to prevent howling and feedback. The output of the Bandpass is also fed over to the RX notch filter U301C through a nulling pot. When the Bandpass filter has been tuned to the appropriate frequency for the desired Guard Tone (usually 2175 Hz) its output is fed through the nulling pot and R303 and R346 where it mixes with audio from R324 coming from the compressor. These two signals cancel at the summing input of Notch filter U301C thus removing the continuous Guard Tone audio leaving only the resulting voice and dialing audio to be transmitted through the volume control SR601B to the speaker amplifier.

Keypad beeps are also input on this same pot to be heard out the speaker. When the handset is taken off-hook, the magnetic reed switch located inside of the handset opens it's contact which signals the microprocessor to activate transistor Q302. Activating transistor Q302 mutes the speaker amplifier. Audio from U301C is fed into ear level RP304 which drives the earpiece driver Q303B to drive the handset earpiece. There is also an ear mute transistor Q304 that allows the microprocessor to mute the earphone. There is also a jumper JP302 that feeds handset mic audio back into the earpiece for sidetone. This jumper should not be used in 4-line duplex mode. There is another jumper JP201 that feeds DTMF and paging and dialing tones into the RX audio path so that they can be heard during the dialing time.

TX Audio Output Path: Mic bias is developed with R100, R134 and R101. This provides mic bias to either the internal mic, or gooseneck mic. These are all electret type mics. When using the internal mic or gooseneck mic, Q306 switches audio into the mic amp U101A where the gain is set by RP101. Q101 on the input of the mic amp kills mic audio during the High-Level function tones and dialing times. Coming out of the mic amp the audio level is approximately 200 mv peak to peak where it is fed into the compressor U102A. The audio out of it is also about 200 mv peak to peak and will change no more than 3 db over a 30-35 db input change. It is then fed into notch filter U103C and U103D. This notch filter is usually set to the standard Guard Tone of 2175 Hz and is designed to remove 2175 Hz components from the voice so that they do not mix with the 2175 tone generator and cause phase cancellation and thus momentary breaks in the Low-Level Guard Tone. The notch filter feeds into the audio mixer along with the signaling and dialing tones from the digital to analog converter. The tones and voice out of the audio mixer are presented to the TX line level pot RP202 and then to the line amplifier U201A. U201A then feeds the top winding of T201. When the line level pot RP202 is set all the way to maximum it is sufficient to drive a single phone line with up to 8 additional tone remotes to about +10 db on the high level guard tone.

The regulator has an input from a wall charger of around 16-20 volts which is passed through a auto-resettable polyswitch F601 into transient absorber TZ601, then through the volume control on/off switch SR601A to an RF bypass cap C602, across several filter caps into the input of the 13.4 volt regulator. D601 is a reverse polarity diode that will blow the auto-resettable polyswitch if the power is reversed. Powering off for one to two seconds will reset the polyswitch. The output of the 13.4 volt regulator is fed to all of the analog circuitry on the analog schematic page. U303A has a voltage divider R373 and R374 that creates the analog pseudo ground reference to all of the op amps on the analog schematic page.

Digital Circuit

There are three microprocessors on the digital schematic page. U402 controls the keypad interface and also talks to the LCD. In addition it generates the keyboard beeps to the speaker amp, it controls the speaker mute when the handset is taken off-hook. Additionally, it controls the Line 2/Supervisor to the line relay on the analog page.

Microprocessor U401 generates the Guard Tone, function tones and signaling tones on its B0-B7 port. These tones are fed into U405 the DAC output over to the analog page. U401 also controls PTT disable, PTT mic enable and ear mute. Both of these microprocessors get their voltage from 5-volt regulator U601.

Microprocessor U403 controls the printer option U404 and decodes the high and low level guard tone, as well as the function tones.

Microprocessor U407 is the real time clock chip with battery back-up.

U508 is the MDC-1200 decoder chip.

TECHNICAL NOTES

No technical notes are available at this time.

MIDIAN CONTACT INFORMATION

MIDIAN ELECTRONICS, INC.
2302 East 22nd Street
Tucson, Arizona 85713 USA

Toll-Free: 1-800-MIDIANS

Main: 520-884-7981

E-mail: sales@midians.com

Web: www.midians.com

- This page intentionally left blank -

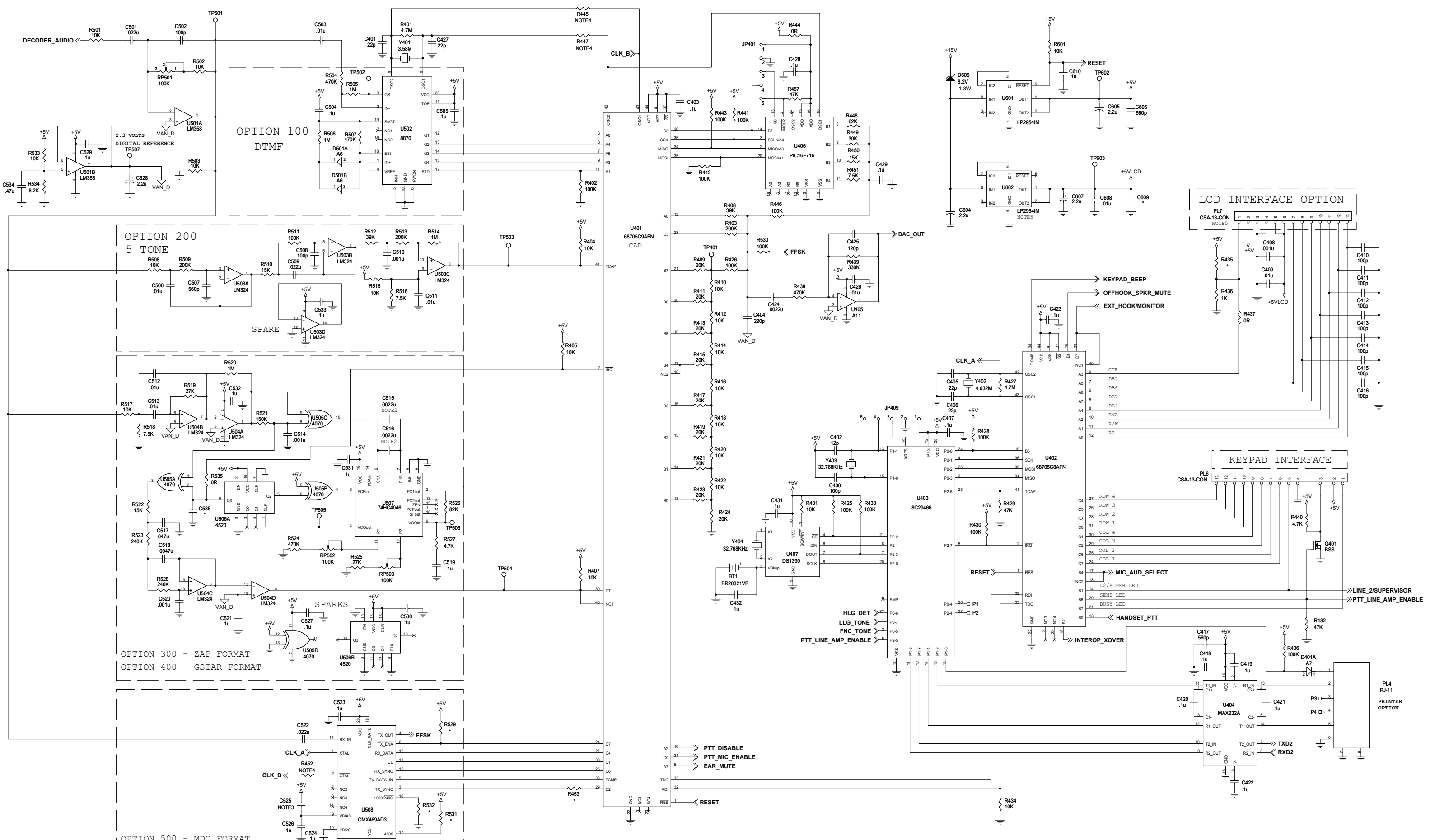

FOR NOTE INFORMATION, PLEASE SEE ANALOG PAGE.

MIDIAN ELECTRONICS, INC.		TRC SERIES		REV	FILE NAME
DATE	NOV. 16, 2004	DWN BY	AWS	G-1	TRC-500
DESIGN	CJS	REV.	07/06/2008	SIZE	SHEET
				D	DOCUMENT NUMBER
					1 of 2
					500-MCU

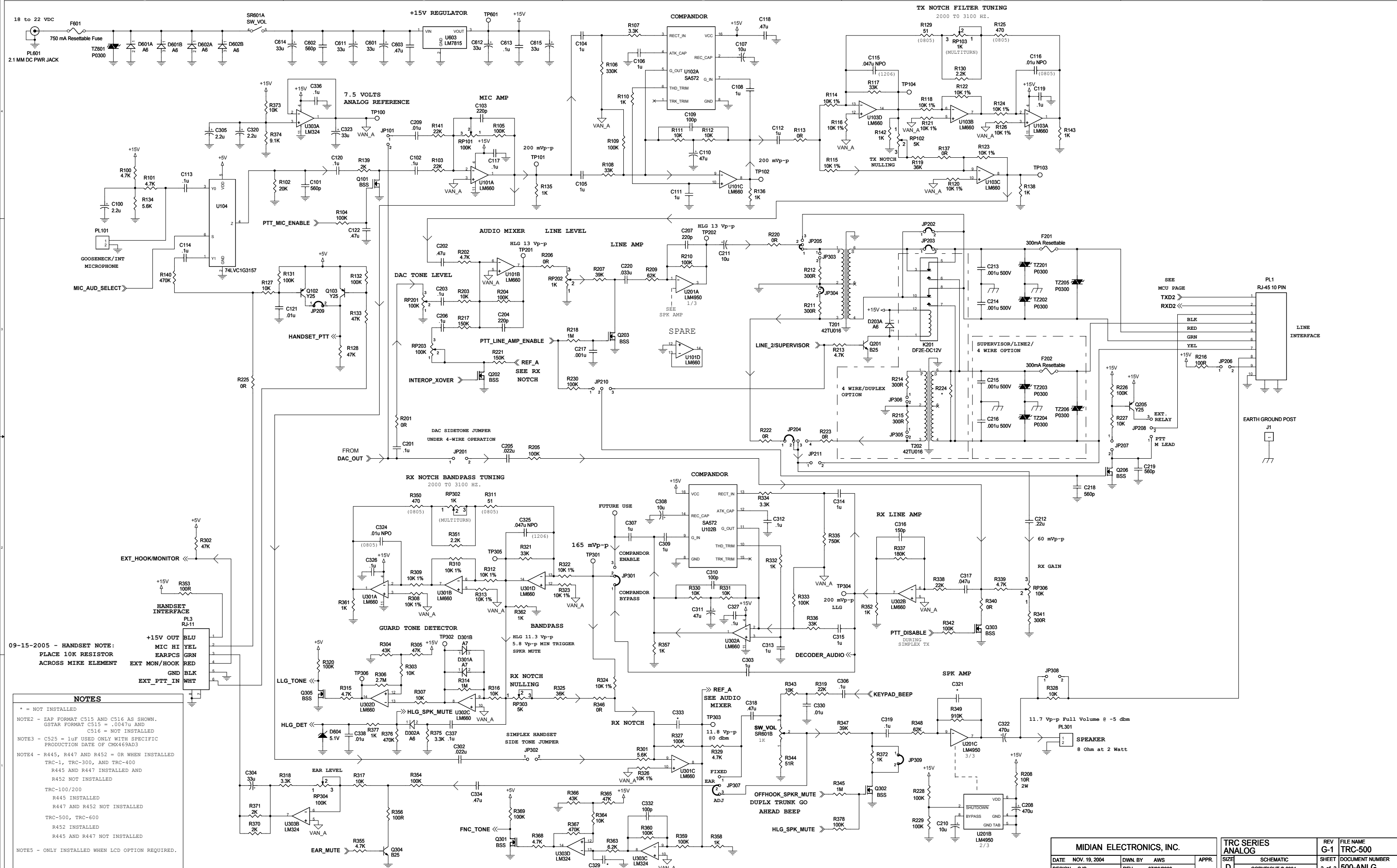

09-15-2005 - HANDSET NOTE:
 PLACE 10K RESISTOR
 ACROSS MIKE ELEMENT

BLU +15V OUT
 YEL MIC HI
 GRN EARPCS
 RED EXT MON/HOOK
 BLK GND
 WHT EXT_PTT_IN

NOTES

* = NOT INSTALLED

NOTE2 - ZAP FORMAT C515 AND C516 AS SHOWN.
 GSTAR FORMAT C515 = .0047u AND
 C516 = NOT INSTALLED

NOTE3 - C525 = 1uF USED ONLY WITH SPECIFIC
 PRODUCTION DATE OF CMX469AD3

NOTE4 - R445, R447 AND R452 = OR WHEN INSTALLED
 TRC-1, TRC-300, AND TRC-400
 R445 AND R447 INSTALLED AND
 R452 NOT INSTALLED

TRC-100/200
 R445 INSTALLED
 R447 AND R452 NOT INSTALLED

TRC-500, TRC-600
 R452 INSTALLED
 R445 AND R447 NOT INSTALLED

NOTE5 - ONLY INSTALLED WHEN LCD OPTION REQUIRED.

MIDIAN ELECTRONICS, INC.		TRC SERIES ANALOG		REV G-1	FILE NAME TRC-500
DATE NOV. 19, 2004	DOWN BY AWS	APPR.	SIZE	SHEET 2 of 2	DOCUMENT NUMBER 500-ANLG
DESIGN CJS	REV. 07/06/2008		D		

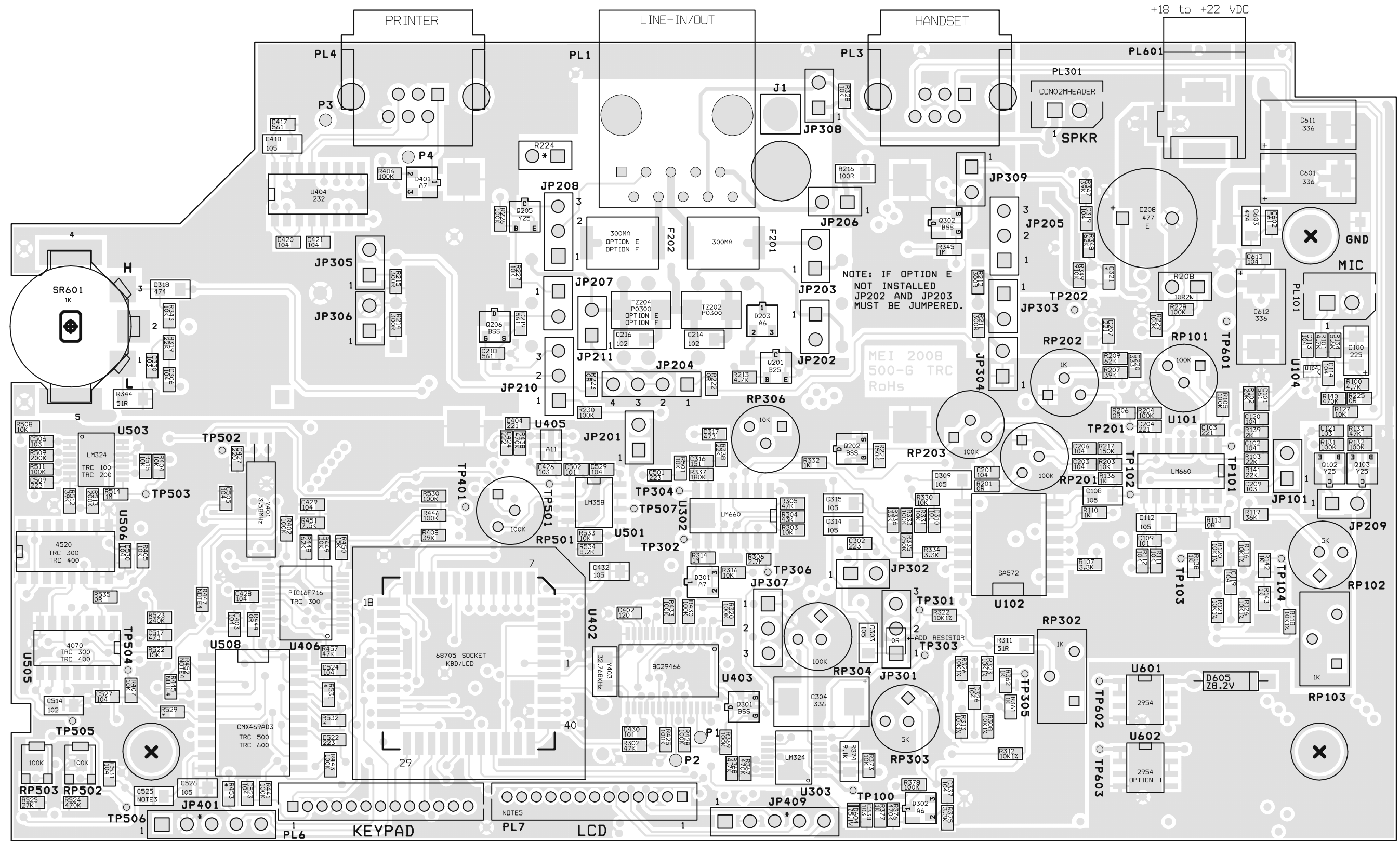

TRC 300
INSTALL U406 = PIC16F716

WHEN INSTALLED R445, R447
AND R452 = 0 OHMS

TRC 100/200/1000 (NOTE4)
R445 INSTALLED
R447 AND R452 NOT INSTALLED

TRC 1/300/400 (NOTE4)
R445 AND R447 INSTALLED
R452 NOT INSTALLED

TRC 500/600 (NOTE4)
R452 INSTALLED
R445 AND R447 NOT INSTALLED

* = NOT INSTALLED
TRC 500/600 (NOTE3)
TESTING ADDS C525 = 1UF(105)
ONLY IF EXCESSIVE CHATTER
EXISTS ON U508

MIDIAN ELECTRONICS, INC.		
DATE: 12/21/2004	DWN. BY: AWS	APPR.
DESIGN: CJS	REV. 07/06/2008	

TRC-SERIES	REV G-1	PROJECT NAME PRJ_500_TRC
COMPONENT	SHEET 1 of 2	DOCUMENT NUMBER 500-G
COPYRIGHT 2008		

TRC1 (NOTE 5)
HAS NO LCD DISPLAY UNLESS
OPTION I IS ORDERED

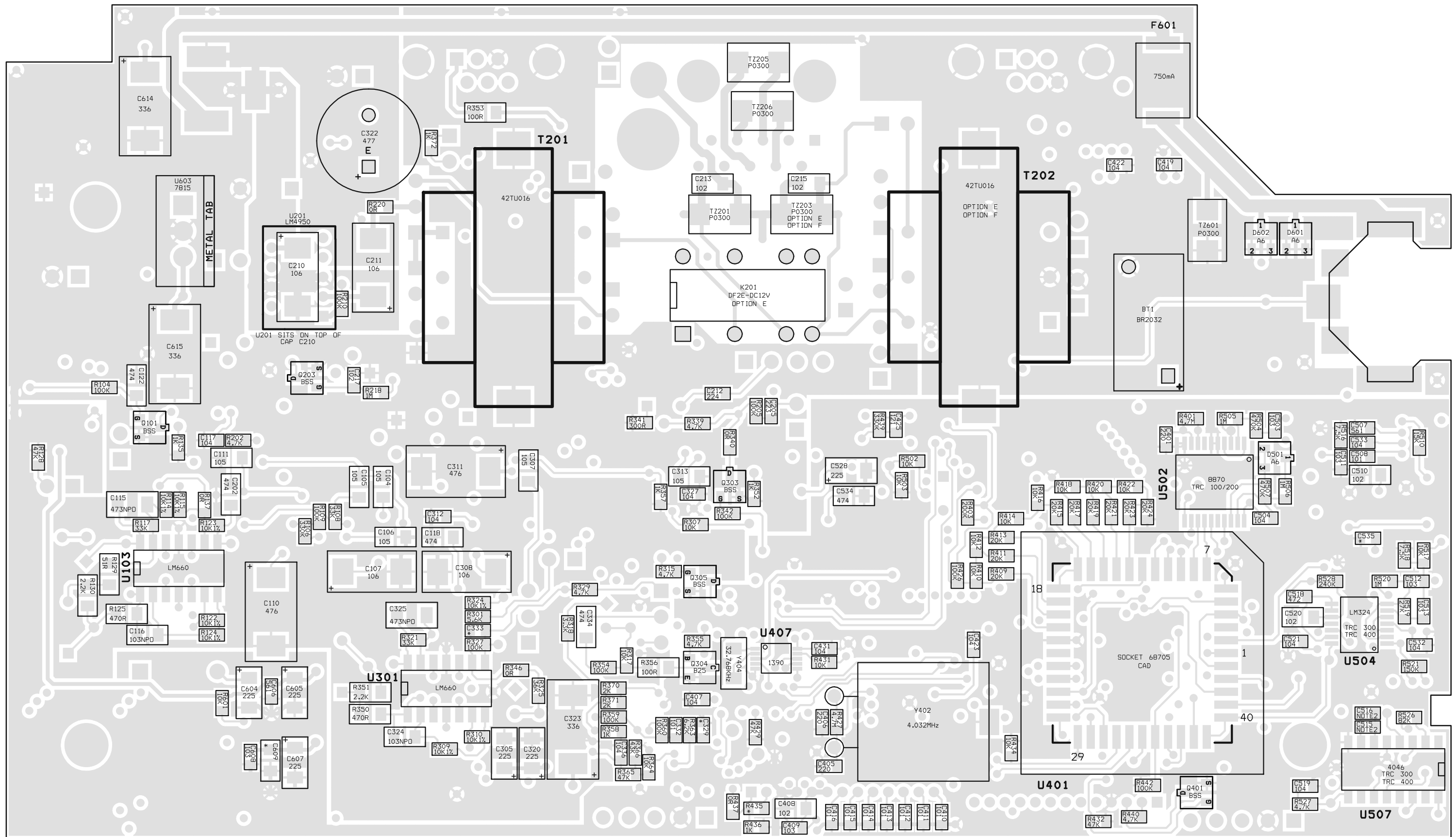

MIDIAN ELECTRONICS, INC.		
DATE: 12/21/2004	DWN. BY: AWS	APPR.
DESIGN: CJS	REV. 07/06/2008	

TRC-SERIES
SOLDER
COPYRIGHT 2008

REV	PROJECT NAME
G-1	PRJ_500_TRC
SHEET	DOCUMENT NUMBER
2 of 2	500-G

* = NOT INSTALLED
 TRC 300 (NOTE2)
 INSTALL C515 & C516
 WITH .0022UF (222)
 TRC 400 (NOTE2)
 INSTALL C515 = .0047UF (472)
 C516 = NOT INSTALLED

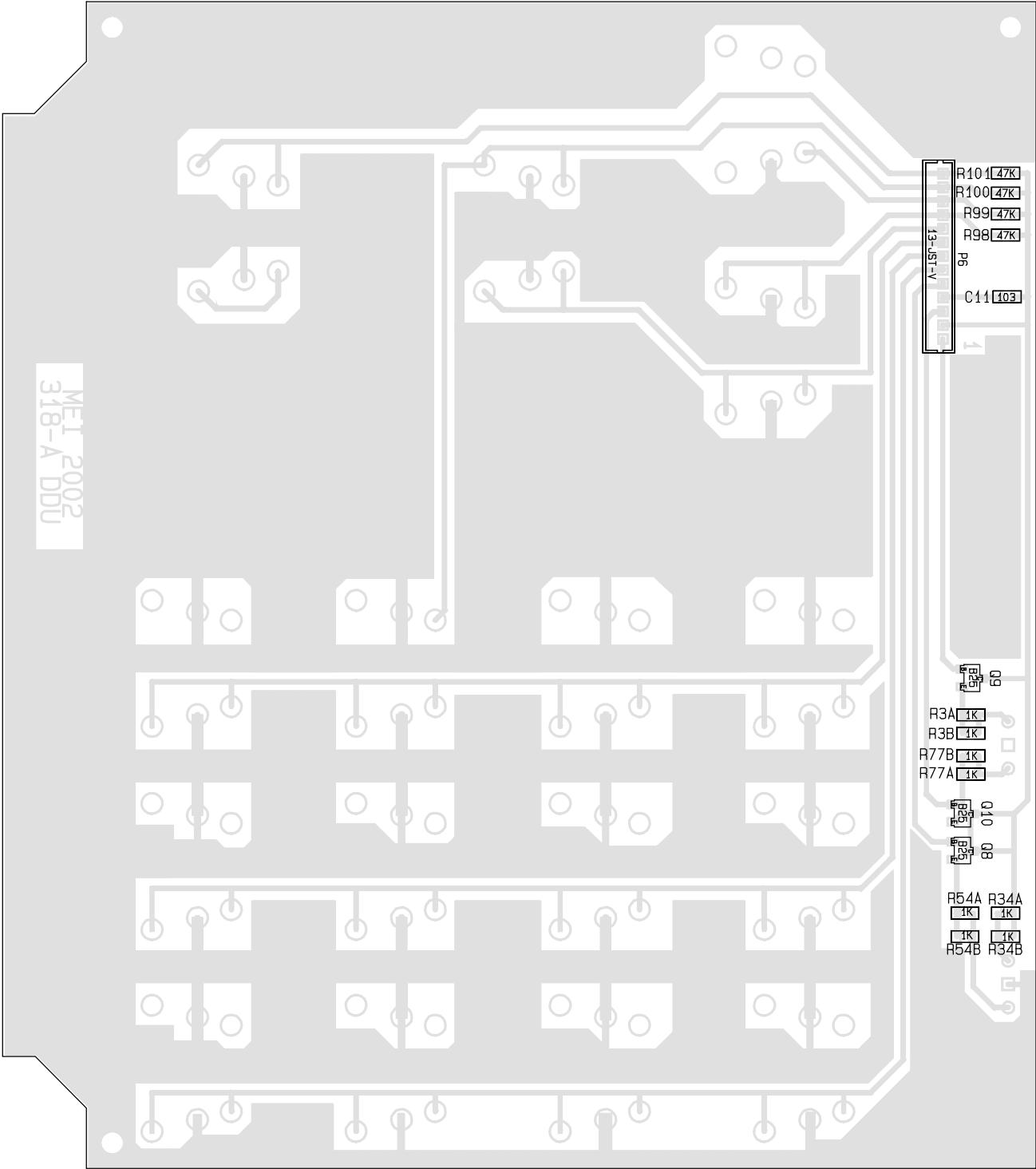

MET 2002
318-A DDU

- R101 [47K]
- R100 [47K]
- R99 [47K]
- R98 [47K]
- or
- C11 [103]
- 60
- R3A [1K]
- R3B [1K]
- R77B [1K]
- R77A [1K]
- 60
- 60
- R54A [1K]
- R54B [1K]
- R34A [1K]
- R34B [1K]

MIDIAN ELECTRONICS		MIDIAN		
DATE	MAY 2K	DWN.BY	AB	APPR.
DESIGN	CJS	REV.	FEB 16/02 AB	

DDU SERIES		REV.	FILE NO.
PICTORIAL		B	318RB.PCB
COPYRIGHT © 2002		SHEET	DWG. NO.
			318.CHP

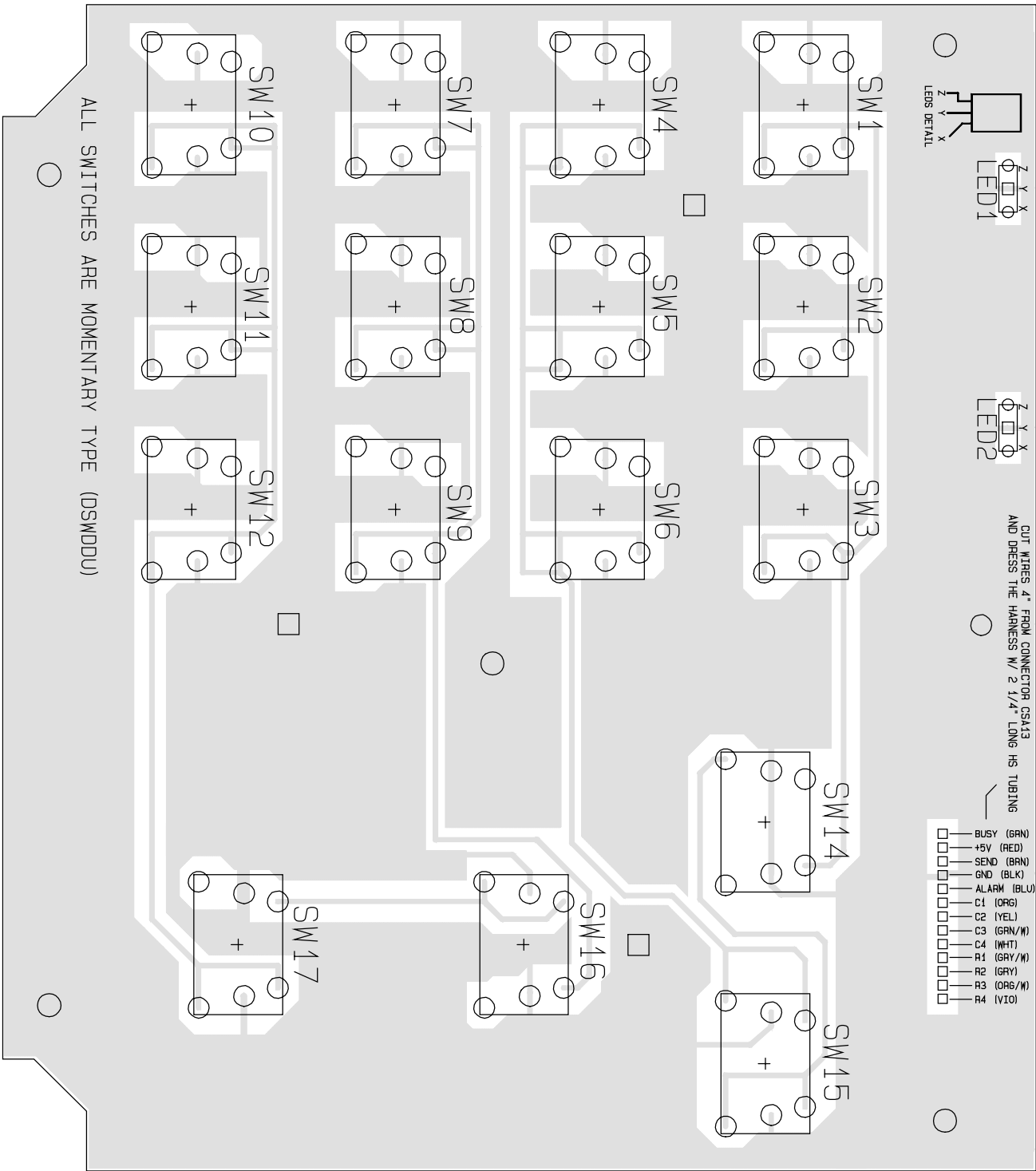

MIDIAN ELECTRONICS		MIDIAN		
DATE	MAY 2K	DWN.BY	AB	APPR.
DESIGN	CJS	REV.	FEB 16/02 AB	

DDU SERIES		REV.	FILE NO.
PICTORIAL		B	318RB.PCB
COPYRIGHT © 2002		SHEET	DWG. NO.
			318.CHP

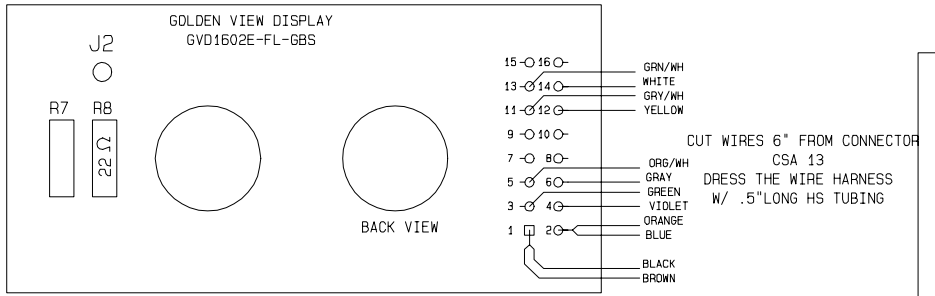

REMOVE EXISTING RES RB. REPLACE WITH 22 Ohm
INSTALL JUMPER J2 WHEN THERE IS PROVISION FOR IT.

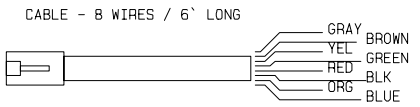

MIDIAN ELECTRONICS				DDU/PDE1 PAGING & DIALING ENCODER		REV. B	FILE NO. 318B.SCH
DATE MAY 00	DWN.BY AIB	APPR.	SCHEMATIC		SHEET	DWG.NO. 318.CHD	
DESIGN CJS	REV. APR 9/03 AB		COPYRIGHT © 2003				

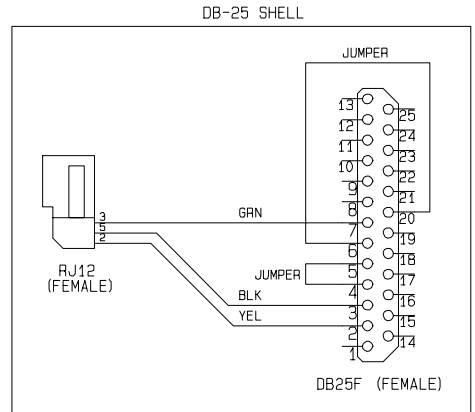
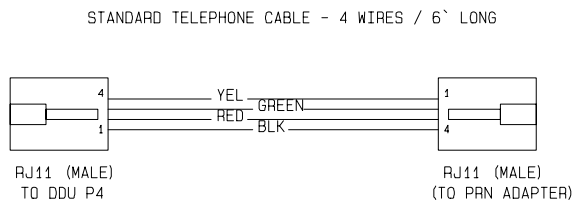

NOTE: BLUE, RED AND WHITE WIRES ARE NOT USED

MIDIAN ELECTRONICS				DDU/PDE1 PAGING & DIALING ENCODER		REV. B	FILE NO. 318B.SCH
DATE 6/02	DWN.BY AIB	APPR.	SCHEMATIC		SHEET	DWG.NO. 318.CHD	
DESIGN BB	REV. APR 9/03 AB		COPYRIGHT © 2003				