



Installation Manual

VS-1200

Frequency Domain Scrambler with Multi-Format ANI

VS-110

Rolling Double Inversion Scrambler

VS-115

Rolling Double Inversion Scrambler with Multi-Format ANI

VS-1100

Double Inversion Scrambler

VS-1150

Double Inversion Scrambler with Multi-Format ANI

VS-1000

Voice Inversion Scrambler

VS-1050

Voice Inversion Scrambler with Multi-Format ANI

Manual Revision: 2018-04-03 Rev E

Covers Firmware Revisions:

VS1xxx: 01.80.00 & Higher

Covers Hardware Revisions:

VS1xxx: 7359E & Higher

HARDWARE SPECIFICATIONS

Operating Voltage	4.75-15.5 VDC***
Operating Current – VS-1200, VS-110 & VS-1100:	
Power Save Mode (COR Operation)	2.5 mA typical
Power Save Mode (VOX Operation)	10 mA typical
Clear or Inversion Operation	29 mA typical
FFT Scrambling Operation	83 mA typical
Average w/COR Power Save (80-10-10 cycle)	<17 mAh*
Average w/COR Power Save (90-5-5 cycle)	~10.5 mAh*
Operating Current – VS-1000 & VS-1050:	
Power Save Mode (COR Operation)	2.5 mA typical
Power Save Mode (VOX Operation)	10 mA typical
Clear or Inversion Operation	17.5 mA typical
Average w/COR Power Save (80-10-10 cycle)	<5 mAh*
Average w/COR Power Save (90-5-5 cycle)	<4 mAh*
Operating Temperature	-30 - +60 C
Frequency Response	300-3000 Hz**
Input Impedance	>45 kΩ
Input Level (TX)	0.05-2.5 VPP
Input Level (RX)	0.05-2.5 VPP
Audio Output Impedance	< 1200 Ohm
Dimensions	~1.6" L x 0.83" W x 0.21" H

* - The transmit and receive cycles are based on FFT scrambling mode. When using clear mode or voice inversion, the consumption will decrease.

** - This is based on FFT scrambling. When using voice inversion this will vary.

*** The VS-1000 and VS-1050 support 4.75 to 15.5 VDC. The VS-1200 supports 4.75 to 10 VDC. If a higher voltage input is needed on the VS-1200 a 4.7 Volt Zener diode must be installed in series with the voltage input lead.

SECURITY SPECIFICATIONS

VS-1200:

Total Code Combinations	~6.2 x 10 ²³
Actual Code Combinations	~4 Billion
Number of Selectable Keys	3
Levels of Security	4
Inversion	2100-4100 Hz (0-15 Hz resolution)
Level 1	16 bins
Level 2	32 bins
Level 3	64 bins

VS-1100 & VS-1150:

Total Number of Codes	32
Number of Selectable Codes	16

VS-1000 & VS-1050:

Number of Selectable Keys	16
Inversion Frequency Range	2100-4100 Hz (0-15 Hz resolution)

VS-110 & VS-115:

Total Number of Codes	1020
Number of Codes	255
Number of Groups	4
Number of Selectable Codes	16

ANI SPECIFICATIONS

DTMF ANI Length	Up to 6-digits
DTMF ANI Timing	60/40 msec (Programmable)
5-Tone ANI Length	Up to 6-digits
5-Tone ANI Timing	Programmable
G-Star ANI Range	0001-9999
G-Star ANI Timing	320 msec
Motorola's MDC-1200 ANI Range	0000-FFFF
Motorola's MDC-1200 ANI Timing	~180 msec
Kenwood's FleetSync Unit ID Range	1000-4999
Kenwood's FleetSyncUnit ID Timing	~100-150 msec
Midian's FMP length	~264msec
Midian's FMP ID and Group range	0-9 and A-F
FMP ID length	5 Digits
FMP Group length	3 Digits

GENERAL INFORMATION

VS-1200:

The VS-1200 is a Digital Signal Processor (DSP) based Frequency Domain voice scrambler offering a high level of voice privacy. The DSP converts the analog signal into quantized digital data. It then converts the "Time Domain" signal into the "Frequency Domain". This results in an audio "frequency spectrum", which is then partitioned into bins that are encrypted by the non-linear key generator. The digitized data is converted back to the analog realm using a digital to analog converter.

The above technique and the lack of synchronization result in excellent audio quality, high security and enable the VS-1200 to be used in virtually any type of radio system. These systems include HF SSB, Conventional Two-Way, Trunking, Voting and Simulcast.

In addition to the radio encryption functions the VS-1200, VS-1150 and VS-115 offers ANI and Emergency ANI encode in the following formats:

- Motorola's MDC-1200
- Kenwood's FleetSync
- Harris' G-Star (aka GE-Star)
- DTMF
- 5-Tone (all formats)
- Midian's FMP (encode and decode) with auto descramble*

*Auto-Descramble is available on the VS-1200, 1150 and 1050 only. The Packet Based Auto Descramble uses our FMP signaling and the Tone Based Auto Descramble uses a pilot tone to cause the receiving scrambler to automatically decode scrambled audio, independent of the mode switch setting. The VS-110 and 115 already have auto-descramble built into it, for this reason Midian does not recommend using the FMP for auto-descramble in the VS-110 and 115.

VS-110:

Midian's VS-110 is a rolling double inversion scrambler that offers 1020 possible codes (4 groups with 255 codes per group). Of these codes the scrambler may be programmed with up to 16 of these codes. The VS-110 series is compatible with Icom's UT-110.

VS-1100:

Midian's VS-1100 is a double inversion scrambler (aka split-band scrambler) that offers 32 possible codes. Of these 32 codes the scrambler may be programmed with up to 16 of these codes. The VS-1100 series is compatible with Midian's VPU-6, Icom's UT-109 and UT-112 or Inysa's XPTO. A table showing the code relationships between manufacturers is in the on line help in the VS-1100 MPS software.

VS-1000:

Midian's VS-1000 voice inversion scrambler provides an entry level of voice security for two-way radio communications. The VS-1000 provides up to 4 different inversion frequencies that are button selectable. These inversion frequencies are programmable using Midian's KL-4. The VS-1000 is compatible with Midian's VPU series voice inversion scramblers.

Note: For more information on Midians FMP and the VS-115, VS-1150 and VS1050 please see the VS-series Technical Reference Manual.

INSTALLATION OVERVIEW

1. Test the radio for functionality.
2. Program the radio per the Radio Programming Section of this manual.
3. Install the scrambler into the radio per the Hardware Installation Section of this manual.
4. Program the scrambler per the Product Programming Section of this manual.

Note: Midian is not responsible for any damage/loss resulting from the use of Midian's products.

RADIO PROGRAMMING

For any programming instructions for a particular radio, please consult Midian's application notes for the VS series, if available.

HARDWARE INSTALLATION

Be certain to follow standard anti-static procedures when handling any of Midian's products. For installation instructions into a particular radio, please consult Midian's application notes for the VS series, if available.

Before installing the scrambler, follow the audio alignment procedures starting on page 9.

For all diode protected inputs (i.e. PTT Input, Mode Input, COR Input) the voltage level to be required for a logic low is less than 0.5 V and a logic high requires at least 2.1 V.

P1 – Connector Side

P1-1 – Green – PTT Input – Connect the PTT Input lead to the high side of the PTT switch.

P1-2 – Red – VIN +4.75-15.5 VDC – Connect to switched battery point in the radio. Connect to a regulated voltage point in a vehicular radio if engine noise is present on the battery line. Keep this lead as short as possible. The VS-1000 and VS-1050 support 4.75 to 15.5 VDC and the VS-1200 supports 4.75 to 10 VDC. If a higher voltage input is needed on the VS-1200 a 4.7 Volt Zener diode must be installed in series with the voltage input lead.

P1-3 – Brown –Mode/code Select – Connect to a momentary or latching switch. If a latching switch then code select is only available using the binary code select lines (P2-3 to P2-7 below).

P1-4 – Black – Ground – Connect to the nearest ground plane in the radio.

P1-5 – Blue – TX Audio In – The unit must be installed in the TX audio path between the microphone and the insertion point of CTCSS or other tone signaling. Break the TX audio path and connect to the side nearest the microphone.

P1-6 – Orange – Emergency Input – Only needed with the VS-1200, VS-1050 VS-1150 or the VS-115 when using the Emergency ANI feature. Connect to a switch, that when triggered will activate the emergency alert.

P1-7 – Yellow – RX Audio In – The unit must be installed in the receive audio path after the CTCSS high pass filter and where any tone signaling is picked off. This point needs to be given a constant level. If possible connect to the high-side of the volume control where a constant level is available. Connect to the source of the audio at the break.

P1-8 – Green/White – Audio Enable Out - This output is active whenever the unit beeps such as when indicating mode. Connect this lead to a point in the radio, which will turn on the radio's speaker power amp, allowing beep tones to be heard.

P1-9 – White – PTT Out – Only needed with the VS-1050 and VS-1200 when using the ANI features. Connect to the same point as P1-1. PTT Output should be connected even when using common PTT mode.

P1-10 – Gray/White – RX Audio Out – Connect to the side closest to the receiver's speaker driver amplifier at the above mentioned break point (see P1-7). In addition to outputting receive audio, this lead outputs beep tones whenever applicable, such as when the mode switch is pressed.

P1-11 – Gray - Mode Out – If desired, connect to the cathode of an LED with a 1 K limiting resistor in series connected to a voltage source up to 15 V. Failure to include a current limiting resistor in series with the LED will cause damage. This output is used to provide a visual indication of scramble or clear mode. Another application of this output is to provide a logic level (high or low (0-3.3 V) to indicate mode to the radio's mode indication icon (if applicable).

P1-12 – Orange/White – TX Audio Out – Connect to the point nearest the modulator at the above-mentioned breakpoint (see P1-5).

P1-13 – Violet – COR Input – Connect to a point in the radio receiver squelch circuit that changes state when carrier is present.

P2 – Non-Connector Side

P2-1 – Program Input – Connect the green clip lead from the KL-4 programmer to this point or Pad 3.

P2-3 – Code Select 0 – This line would be connected to Binary Select 1. For 2-line to 4-line binary this would be the least significant bit (LSB). Note: The VS-1200 can only use 1-line or 2-line binary as it is only capable of 3 codes. The VS-110, VS-1100, VS-1000 and VS-1050 can support up to 4-linebinary for 16 codes.

P2-5 – Code Select 1 – This line would be connected to Binary Select 2. In 2-line binary mode this is the most significant bit (MSB).

P2-6 – Code Select 2 – This line would be connected to Binary Select 4. In 3-line binary mode this is the most significant bit (MSB).

P2-7 – Code Select 3 – This line would be connected to Binary Select 8. In 4-line binary mode this is the most significant bit (MSB).

P2-8 – Monitor/LTR Input – This input is currently available for use as a trunking delay input. Connect this input to a point in the radio that goes low or high when a channel is acquired. Program the scrambler with the active polarity. This input only needs to be connected when using leading ANI in the VS-1200, VS-1050, VS-1150 and VS-115

P2-12 – Program Output – Connect the yellow clip lead from the KL-4 programmer to this point or Pad 4.

Note: Greater details of the VS series products can be found in the VS Series Technical Reference Manual. Midian's VS series radio encryption is programmed via Midian's KL-4F and the MPS software. Please reference the KL-4 manual for setup instructions of the KL-4 hardware.

KL4-F USB PORT ASSIGNMENT and SOFTWARE INSTALLATION

Go to our website midians.com and under downloads> software download the latest MPS software version. If using the supplied CD-ROM insert it into the PC's CD-ROM drive. In the browser that will pop-up, install the MPS programming software. Be certain that the "Install KL-4 USB Driver" box is checked during the installation process.

Open Windows' Control Panel and go to Device Manager.

Open Ports (COM& LPT) to identify the port assignment issued by computer. Plug in the KL4 programmer to the USB port and the screen will flash and show the device location.

Open the software and choose product from product tree then set appropriate comport selection in the MPS software as needed

After entering the parameters, save the file by going to File - Save As. Enter the file name in the File Name block and click Save. Saving the file will allow for quick and easy reprogramming of units.

After the latest MPS has been installed default programming files for specific radio models can be found at: C:\Apps\Midian\MPS\MPS_v5_xx\Additional Default Files\VS-1xxx\Wired

KL-4F Programming: Plug the board onto the KL-4F P4 connector labeled as "P4". Connect the green KL-4F clip lead to the PI* hole (or P2-1). Connect the yellow KL-4F clip lead to the PO* hole (or P2-12). Push and hold the power button on the KL-4F, wait for three seconds and then click "Program Unit" in the MPS software.

KL-4 Reading: Plug the board onto the KL-4F P4 connector labeled as "P4". Connect the green KL-4F clip lead to the PI* hole (or P2-1). Connect the yellow KL-4F clip lead to the PO* hole (or P2-12). Push and hold the power button on the KL-4F, wait for three seconds and then click "Read Unit" in the MPS software.

For location of PI and PO holes please see the pictorial at end of manual

Turn power on to the unit and within 15 seconds select Program Unit or Read Unit in the MPS software. Upon power up the unit will be awake for 15 seconds before going into Power Save mode.

After programming or reading the unit, turn off the unit for 3 seconds and then turn back on.

Note: For the VS-1200 the security pass phrases can use any 8-bit ASCII keyboard characters. These include the characters on a typical English keyboard such as 0-9, A-Z (upper and lower case), *, #, @, \$, etc. Spaces are also allowed. Midian does not recommend using international language characters such as ñ, ä, ß, ü, é, etc. as these have not been tested. Please also note that the pass phrases are case sensitive.

Important Note: Do not attempt to 'clone' the scrambler by reading one and then programming another. When the scrambler is read, the pass phrases will be read out as "<undefined>". If another scrambler is then cloned with this information, the scramblers will be incompatible because they have different pass phrases. To ensure scramblers communicate with each other, program them from a saved *file*.

This section describes how to determine and set the audio levels.

Audio Levels Overview:

To ensure the best audio quality, the scrambler must be configured to match the audio levels used by the radio. The scrambler uses programmable gain amplifiers to accomplish this. Determining the gain settings for these amplifiers is an involved process, so Midian simplified this process by developing an algorithm that requires the technician to make only four voltage measurements. From these four measurements, all of the many internal settings are determined.

Still, getting the best audio quality will likely require a bit of trial and error. The scrambler only has control of audio voltage levels, not input and output impedances. These impedances can dramatically influence the levels.

The Four Voltage Measurements:

An oscilloscope and a communications test set/service monitor are required for the measurements. It is recommended that the measurements be recorded in units of mV peak-to-peak. Each measurement must be taken with system modulation at either 60% or 100%. Most transmitters will not actually modulate at 100%, so 60% is recommended for TX measurements.

These following measurements should be made before installing the scrambler. Also, the measurement procedures assume that the audio pickup and insertion points have already been determined by the installer.

A method for controlling transmit modulation is required for accurate measurements in the TX mode. A small speaker held in place near the microphone by a rubber band can serve this purpose in most cases. Use a sine-wave generator to inject a 1000 Hz tone into the speaker. Adjust the output of the sine wave generator so that the transmitter produces 60% of rated modulation while PTT is pressed. Note that if the audio source (such as a speaker) is moved even slightly, the TX modulation may change significantly. Care must be taken to avoid changing the TX modulation while taking the measurements. Please note that the levels provided to the option board may be different between narrow band and wide band.

In most wired-in applications, a two-terminal component such as a capacitor must be removed from the radio to break the audio path. However, the first two measurements must be taken using a radio that has not been modified. The 2nd two measurements require that power be applied to the scrambler. These measurements must be taken within 15 seconds of powering the scrambler on. This is because the scrambler may enter power saving mode after that time. Measurements made while the scrambler is in power saving mode will not be valid. The unit ships with the power save feature enabled by default. The power save feature can be disabled via the MPS programming software so that it will not interfere with taking measurements, if desired. To do this program the VS-1xxx with a high COR polarity and make sure the violet wire is not attached to anything.

1. **RX Output:** The goal of this procedure is to determine the audio level that would normally appear at the RX audio insertion point in an unmodified radio. Modulate a 1000 Hz tone at either 60% or 100%. Measure the voltage level appearing on the output side of the component that will be removed to break the RX audio path.
2. **TX Output:** The goal of this procedure is to determine the audio level that would normally appear at the TX audio insertion point in an unmodified radio. Provide the radio an audio source generating a 1000 Hz tone and key the radio. Adjust the audio source such that the modulation is at 60%. Measure the voltage level appearing on the output side of the component that will be removed to break the TX audio path.
3. **RX Input:** The goal of this procedure is to determine the audio level that the scrambler board will see at the RX audio pickup point after it is installed. This requires a partial installation of the scrambler, even if only temporary.

The scrambler must be powered-on while making this measurement, so the power input leads of the scrambler must be connected to a switched power source within the radio. Also, the component that will need to be removed to break the RX audio path must be removed. The scrambler board RX input wire must be

connected to the RX audio pickup point. Modulate a 1000 Hz tone at either 60% or 100%. Measure the audio level at RX audio pickup point.

4. **TX Input:** The goal of this procedure is to determine the audio level that the scrambler board will see at the TX audio pickup point after it is installed. This requires a partial installation of the scrambler, even if only temporary.

The scrambler must be powered-on while making this measurement, so the power input leads of the scrambler must be connected to a switched power source within the radio. Also, the component that will need to be removed to break the TX audio path must be removed. The scrambler board TX input wire must be connected to the TX audio pickup point. Provide the radio an audio source generating a 1000 Hz tone and key the radio. Adjust the audio source such that the modulation is at 60%. Measure the audio level at the TX audio pickup point.

Programming the Audio Levels:

After determining the audio levels at the audio hookup points, it will be necessary to program the scrambler to match these levels. In the programming software, there is a slider control on the Audio Levels Screen for each of the of four audio hookup points. Locate the column that corresponds to the modulation and units of measurement for each of the audio hookup points. Adjust the slider bar such that the value appearing in the appropriate column matches what was measured as closely as possible.

OPERATION

Mode Select:

Momentary Switch: When using a momentary switch, pressing and then releasing the switch will cause the scrambler to switch modes. A medium tone followed by a high tone indicates the scrambler has been switched into scrambled mode. A medium tone followed by a low tone indicates the scrambler has been switched into clear mode.

Latched Switch: When using a latched switch, the position of the switch will indicate the selected mode and depending on the programmed polarity one position or the other will indicate scramble mode. For example if the polarity is programmed as low, then the scrambler will be in scrambled mode when taken to ground. When using a latched switch, multi-code operation is only available using the binary code select lines.

Code Select:

Momentary Switch: When using a momentary switch, pressing and holding the switch will toggle the scrambler through the programmed codes (1-3 codes) if programmed. The scrambler will emit a number of tones corresponding to the code that is being switched to. When the desired code is reached simply release the switch.

1-Line Binary: If using the binary mode and up to 2 codes are programmed this provides selection of 2 codes depending on the state of the code select line.

2-Line Binary: If using the binary mode and up to 4 codes are programmed this provides selection of up to 4 codes depending on the state of the code select lines. Note: The VS-1200 only supports up to 3 codes.

3-Line Binary: If using the binary mode and up to 8 codes are programmed this provides selection of up to 8 codes depending on the state of the code select lines. Note: The VS-1200 only supports up to 3 codes.

4-Line Binary: If using the binary mode and up to 16 codes are programmed this provides selection of up to 16 codes depending on the state of the code select lines. Note: The VS-1200 only supports up to 3 codes.

ANI Operation:

Transmitting ANI: When the PTT Input is pressed and/or released, the VS-1200, VS-1050, VS1150 or the VS-115 will key the radio and transmit the programmed ANI.

Transmitting Emergency ANI: When the Emergency Input is taken high or low (depending on programming) the VS-1200, VS-1050, VS1150 or the VS-115 will key the radio and transmit the programmed ENI for the programmed number of times.

Auto-Descramble (Descramble Options): Auto-Descramble is available on the VS-1200, 1150 and 1050 only. The Packet Based Auto Descramble uses our FMP signaling and the Tone Based Auto Descramble uses a pilot tone to cause the receiving scrambler to automatically decode scrambled audio, independent of the mode switch setting. The VS-110 and 115 already have auto-descramble built into it, for this reason Midian does not recommend using the FMP for auto-descramble in the VS-110 and 115. For more information on Midians FMP signaling please see VS Series Technical Reference Manual.

TECHNICAL NOTES

Radio Compatibility: Midian has taken the utmost care to ensure the option board integrates into the radio with minimal impact to the features of the radio. However, some features may not be available in the radio when an option board is used. If a feature is not available, please contact Midian to see if the feature can be added.

Power Save: In order to limit the impact the scrambler has on the battery life, Midian has implemented a power save function in the VS series. When in power save mode, several actions can bring the unit out of power save. These are button presses, COR, VOX.

Button Press: When the PTT, mode or auxiliary input of the VS is activated the unit will come out of power save mode.

COR: When the COR Input sees activity on the channel the VS will come out of power save mode. Using the COR power save function is preferred over VOX power save. If using the COR detect, then the VOX detect is not available.

VOX: When the scrambler sees voice on the channel the VS will come out of power save mode. If using the VOX detect, then the COR detect is not available.

MIDIAN CONTACT INFORMATION

MIDIAN ELECTRONICS, INC.
2030 N. Forbes Blvd. #101
Tucson, Arizona 85745 USA
Toll-Free: 1-800-MIDIANS
Main: 520-884-7981
E-mail: sales@midians.com
Web: www.midians.com

- This page intentionally left blank -

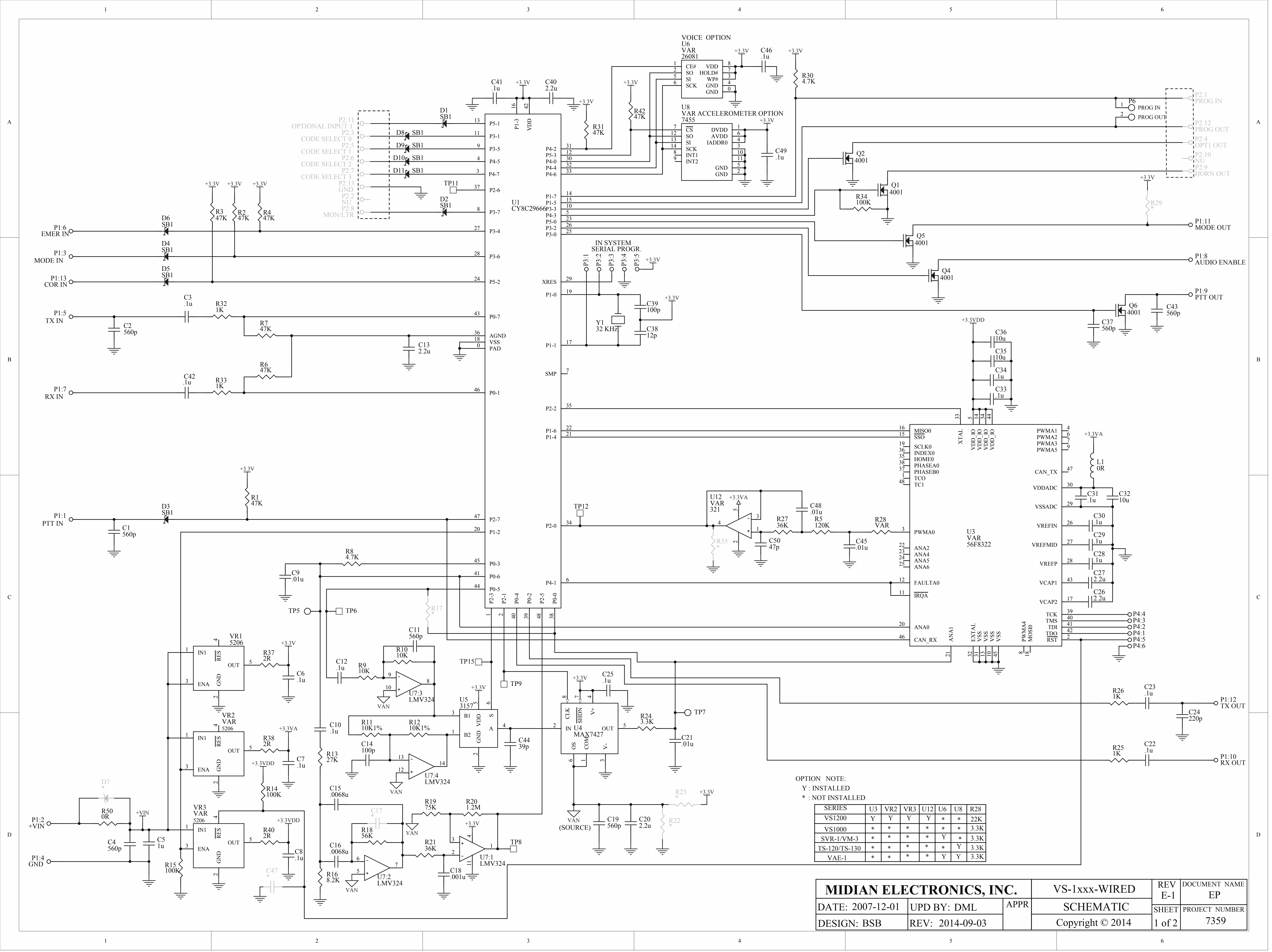

OPTION NOTE:
 Y : INSTALLED
 * : NOT INSTALLED

SERIES	U3	VR2	VR3	U12	U6	U8	R28
VS1200	Y	Y	Y	Y	*	*	22K
VS1000	*	*	*	*	*	*	3.3K
SVR-1/VM-3	*	*	*	*	Y	*	3.3K
TS-120/TS-130	*	*	*	*	*	Y	3.3K
VAE-1	*	*	*	*	Y	Y	3.3K

MIDIAN ELECTRONICS, INC.			VS-1xxx-WIRED	REV E-1	DOCUMENT NAME EP
DATE: 2007-12-01	UPD BY: DML	APPR	SCHMATIC	SHEET	PROJECT NUMBER
DESIGN: BSB	REV: 2014-09-03		Copyright © 2014	1 of 2	7359

-This Page Intentionally left Blank-

SERIES	U3	VR2	VR3	U12	U6	U8
VS-1200	Y	Y	Y	Y	*	*
VS-1000	*	*	*	*	*	*
SUR-1/UM-3	*	*	*	*	Y	*
TS-120/130	*	*	*	*	*	Y
VAE-1	*	*	*	*	Y	Y

* = NOT INSTALLED
Y = INSTALLED

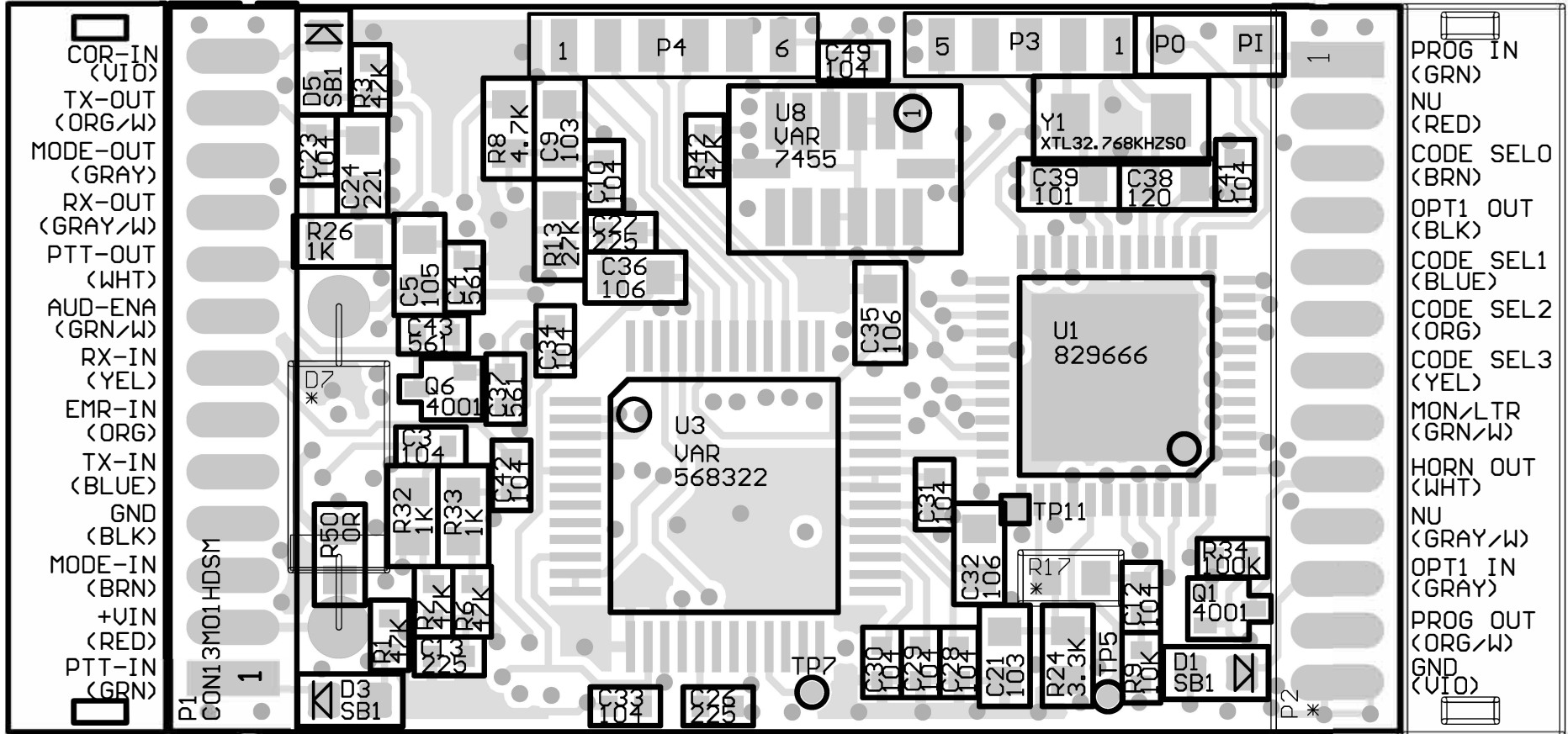

MIDIAN ELECTRONICS, INC.			VS-1xxx-WIRED	REV E-1	DOCUMENT NAME AP
DATE:2007-12-01	DWG BY:DML	APPR	TOP	SHEET	PROJECT NUMBER
DESIGN:BSB	REV: 2014-09-03		Copyright © 2014	1 of 2	7359

SERIES	U3	VR2	VR3	U12	U6	U8	R28
VS-1200	Y	Y	Y	Y	*	*	22K
VS-1000	*	*	*	*	*	*	3.3K
SUR-1/UM-3	*	*	*	*	Y	*	3.3K
TS-120/130	*	*	*	*	*	Y	3.3K
VAE-1	*	*	*	*	Y	Y	3.3K

* = NOT INSTALLED
Y = INSTALLED

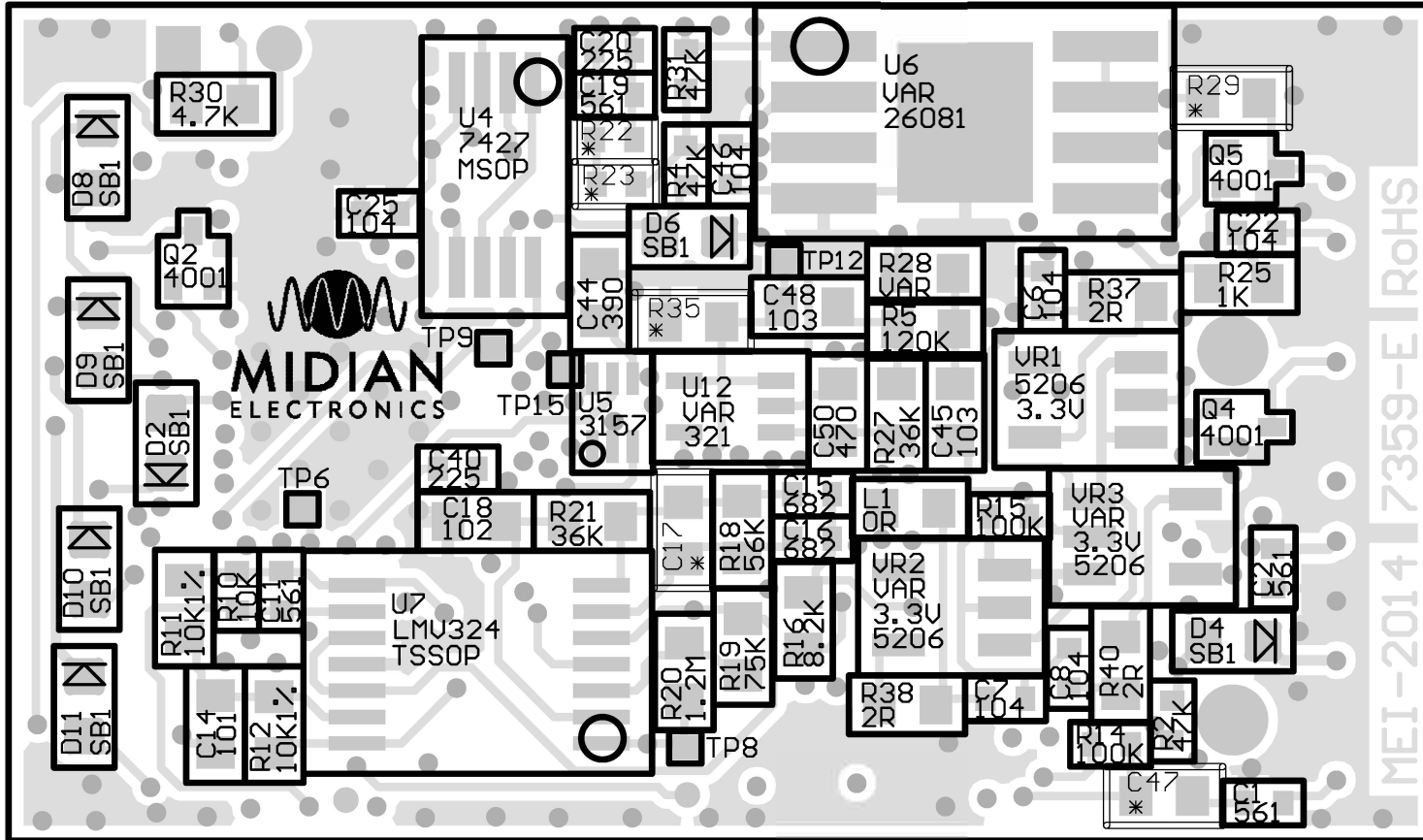

MIDIAN ELECTRONICS, INC.			VS-1xxx-WIRED	REV E-1	DOCUMENT NAME AP
DATE: 2007-12-01	DWG BY: DML	APPR	BOTTOM	SHEET 2 of 2	PROJECT NUMBER 7359
DESIGN: BSB	REV: 2014-09-03		Copyright © 2014		