



Installation Set-up Interface cables

Revision 18

Company Confidential Proprietary

X10DR®
LIBERATE YOUR MOBILE RADIO

Before you start!

X10DR has been designed to allow simple connectivity to most radio models from those dating back from the 90's to the most current digital models from most professional radio manufacturers. Understanding the basic connectivity will allow you to successfully connect to just about any wireless radio device, or to allied wired radio control consoles. The following describes the pin out connectivity of the X10DR mobile charger's 15 pin DB15 connector. Note: pins not described are used for factory set-up and should not have DC voltages or grounds applied to them otherwise the device may be damaged or may cause incorrect operation.

Pin 1. Switched B+ In: Used to automatically turn on/off X10DR by sensing the host radio's status. Normally, this pin connects to a host radio's switched B+ output, if available (no current required), if not, the installer should supply a manual on/off switch for user activation of the unit. Note: The speaker microphone's battery will still charge when the switched B+ is removed.

Pin 2. Transmit Mic Audio Out: This should connect to the host mobile's transmit audio input. This is the audio from the Wireless Microphone that is to be transmitted over the host mobile radio's transmitter. It is factory set for approx 80mV RMS. This can be adjusted up to about 800mV by carefully adjusting the radio audio output VR1 trimpot. (Subject to factory pre-programmed settings. The maximum level can be reset electronically by use of the X10DR Programming kit.)

Pin 3. Radio Mic Lo: This connects to the host mobile's microphone audio ground. Note: on some TDMA digital radios this pin may be best connected to only the shield of the interface cable. This is due to TDMA noise that may be transferred from the host mobile and appear as noise on the X10DR unit.

Pin 4. Receive Audio In: This should connect to the host mobile's receive audio output. This audio source should be under the radio's squelch control and of a level above 40mVrms. Ideally, it should be sourced **pre-volume** control but can be post, as long as the host mobile radio's speaker audio has first been set for comfortable listening in the vehicle before adjusting VR2 trimpot.

Pin 5. DC Power In: This pin should connect via a 1 amp in-line fuse preferably direct to a vehicle's 12V battery but can be any constant voltage from about 6-15VDC. Current consumption is typically 60mA. Max current 220mA@12V. It requires to be constantly connected to ensure the units can recharge when the host mobile may be turned off.

Pin 6. Ext. PTT Out: This pin provides a switched ground output and should connect to the host mobile radio's external PTT input. Some radio models have active high PTT inputs. Those models will require the use of special interface cables that allow the X10DR output to be inverted to an active high.

Pin 7. Emergency Out: This output is intended to connect to the host mobile radio's emergency input. It normally provides an active switched ground (<50mA sink) but can be jumpered to be active open circuit. The time held low (or high) is the exact time that the user presses the Emergency button. This output could be used for other functions such as to trigger the panic function of a car alarm system. On some radios this input is available as standard, on others it requires the host mobile's I/O ports to be first programmed for such.

Pin 8. COR/Squelch/Audio Unmute In: This input is designed to monitor the receive status of the host mobile radio. For best operation it is driven by an "audio unmute" switched ground output from the host mobile. i.e. an indicator of whenever the host radio's speaker unmutes. Alternatively, it should be driven by a switched ground output that indicates the radio's squelch condition. This output should factor reception of the required correct CTCSS tones, etc. On some radios this output is available as standard, on others it requires the host mobile's I/O ports to be first programmed for such. Internal jumpering within the X10DR mobile charger caters for radios with active high outputs.

On some radio devices a COR output is not available without modifying the host mobile. While this would be desirable, the X10DR features smart VOX circuitry to adapt its operation in these cases where a radio COR is not available. In some mobiles there is a DC shift on the radio's speaker output terminal whenever the radio unmutes, which can be used as a COR input. Making use of such requires changes to R40/41 in the X10DR mobile charger. Such configurations requires good technical know-how and care must be taken to NEVER short a mobile radio's bridged audio output to ground.

Pin 9. Ground: This pin should connect to DC / Digital ground connection. Note: on digital radios this is usually NEVER audio ground. Connect to the vehicle's chassis or a solid DC ground from the host mobile.

Pin 13. Remote PTT In: This pin allows you to provide a remote PTT alternative to transmit Secure Wireless Microphone audio over the host mobile radio. You may choose to connect to a motorbike's handle bar PTT, a hidden palm or footswitch or a wireless PTT device. When a headset is connected to a secure wireless microphone's Hirose® audio port the microphone sensitivity is normal.

However, if a headset is NOT attached to the Hirose audio port, then grounding pin 13 causes the X10DR to transmit audio with substantially increased mic sensitivity. This allows *Remote Monitor* to be achieved by using a switched output from the host mobile to remotely activate the function. Thus a control room operator could monitor the user's ambient audio to ascertain the health or safety of the user. Alternatively, this pin can be used with the XFB Special function box for other specialist applications such as Lone Worker.

Internal Jumpering (Original models)

Some alternate interface configurations are available by modifying the internal jumpering of the mobile charger unit. These solder “blob jumpers” are provided to allow compatibility with different mobile radio types.

Re-configuration of these jumpers should only be undertaken by qualified radio service personnel. (Requires precision miniature SMD type hand soldering.)

To access the PCB, first remove the rear mounting plate from the mobile charger. Next remove the 4 case screws to access internal PCB. Take extreme care when handling the PCB to prevent damage by electrostatic discharge (ESD) or to internal wiring. Re-assemble carefully making sure to not damage wiring.

Installation Jumper Configuration:

- For N/C emergency trigger: SJ1 Out SJ2 In (default)
 - For N/O emergency trigger: SJ1 In SJ2 Out
 - For active lo radio COR: SJ3 Out (default)
 - For active high radio COR: SJ3 In
 - For Vox enable: SJ4 In (default)
 - For Vox disable*: SJ4 Out
- (*Warning - may cause some radio supervisory tones to be not heard)

- R40 Default: not fitted - Fit 0 ohm** for DC shift COR detect
 - R41 Default: fitted - Remove for DC shift COR detect
- ** or as appropriate

- J3 Default: In - Remove J3 to prevent the wireless mic speaker from muting when placed inside the mobile charger. This option is generally recommended only when the host radio has no internal or external speaker. Removing J3, may cause the re-charge time to increase significantly on a very busy radio channel.

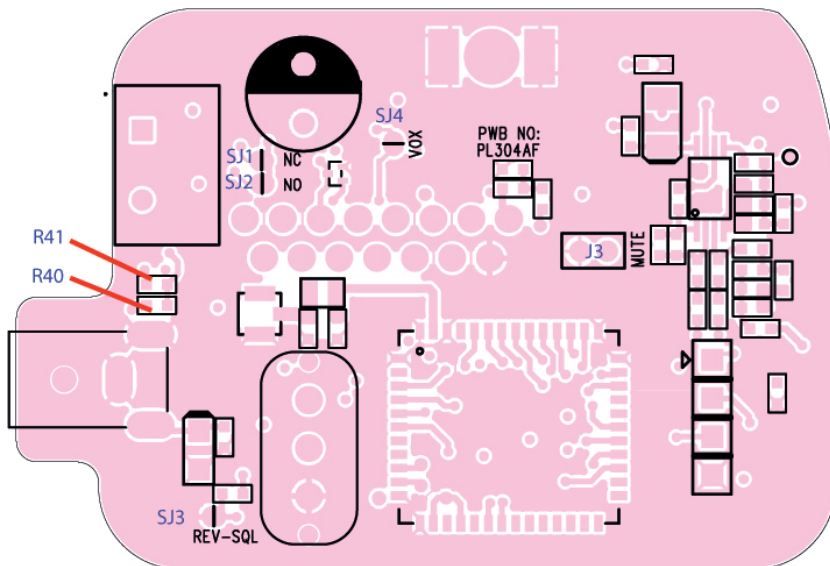

Internal dip switch setting (Post Apr 2014)



From April 2014 the X10DR cradle now features a dip switch array in place of the J3 and solder jumpers.

Some alternate interface configurations are available by modifying the internal dip switch settings of the mobile charger unit. These dip switch settings are provided to allow compatibility with different mobile radio types.

To access the PCB, first remove the rear mounting plate from the mobile charger. Next remove the 4 case screws to access internal PCB. Take extreme care when handling the PCB to prevent damage by electrostatic discharge (ESD) or to internal wiring. Re-assemble carefully making sure to not damage wiring.

Installation Jumper Configuration:

- For N/C emergency trigger: Sw1 On Sw2 Off (default)
 - For N/O emergency trigger: Sw1 OFF Sw2 ON
 - For active lo radio COR Sw3 OFF (default)
 - For active high radio COR Sw3 ON
 - For Vox enable Sw4 ON (default)
 - For Vox disable* Sw4 OFF
- (*Warning - may cause some radio supervisory tones to be not heard)

- Speaker disable in cradle Sw6 ON (default)
- Speaker enable in cradle Sw6 OFF

- R40 Default: not fitted - Fit 0 ohm** for DC shift COR detect
 - R41 Default: fitted - Remove for DC shift COR detect
- ** or as appropriate

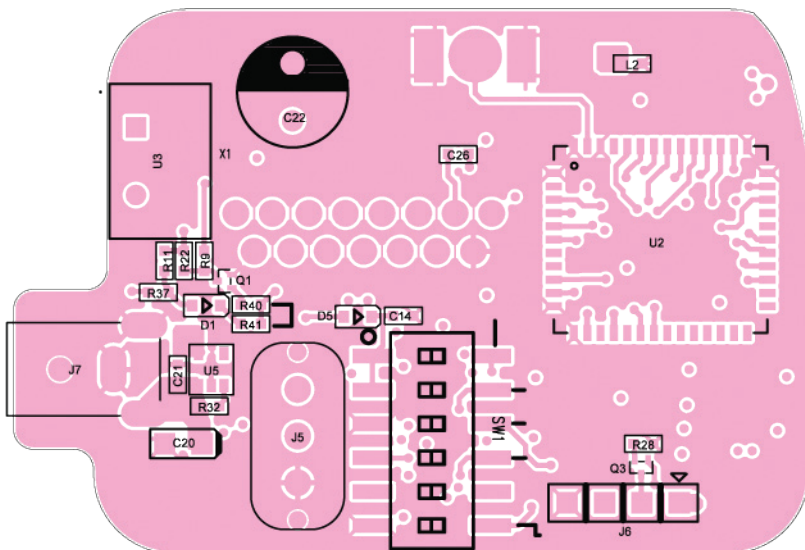

Set Up - Basic Requirements



Radio Programming - VERY IMPORTANT

For correct X10DR operation, the host mobile radio on some occasions will require reprogramming (via its associated FPP/CPS etc) to enable correct functionality. Read carefully this instruction document to get a complete understanding of the interfacing requirements. It is not a difficult interface but it does require common technical practical commonsense when interfacing to other devices. Whilst some manufacturers radios are pre-configured to suit from the factory, others require service shop programming for functions like PTT, COR (channel busy), emergency trigger and audio level settings to be accessible on the radios rear interface connector. Incorrect radio settings may cause distortion or noisy audio, the unit to not function or may damage either the X10DR or host radio if not configured properly.

Adjusting Levels - VERY IMPORTANT

Installation of the X10DR requires setting of audio levels between the X10DR and the host radio. VR1 and VR2 on the base of the X10DR charger can be used to fine tune levels. Use a small Phillips screwdriver (PH1) to carefully adjust the settings. The X10DR is factory set to provide a nominal 80mV audio signal to the host radio's mic input. This level can be adjusted via VR1 to suit the particular radios requirement. VR1 should be adjusted (if necessary) to match the audio level & quality when the X10DR transmit audio is compared with the host radio fist mic transmit audio level & quality (listen via a service monitor, or another radio). VR2 should be adjusted (if necessary) to set a loud and undistorted receive audio signal on the X10DR unit when receiving from a service monitor, or another radio. Make sure the X10DR user volume control is on level 4 before adjusting VR2 (press the right blue button closest to the antenna 5 times and then press the left blue button once). Note: some radios can only provide a volume controlled audio output to the X10DR. In such cases you should first set the host radio speaker volume to a comfortable listening level in the vehicle, and then adjust the X10DR volume to suit.

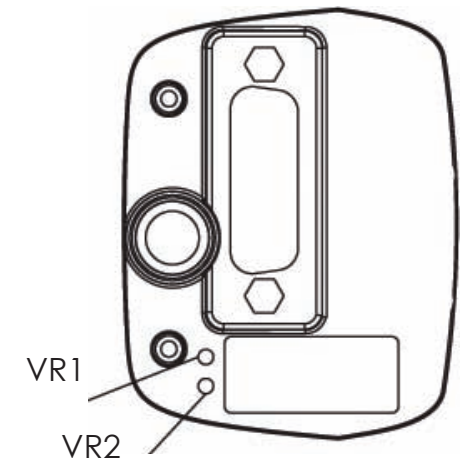

The X10DR mobile charger's trim pots are very delicate and extreme care must be taken when adjusting to prevent physical damage. - NOTE: mechanical damage is not covered by X10DR product warranty!

Mobile charger DB15 connector

Typical wiring diagram (New Generic cable color scheme shown)

DB15 connector

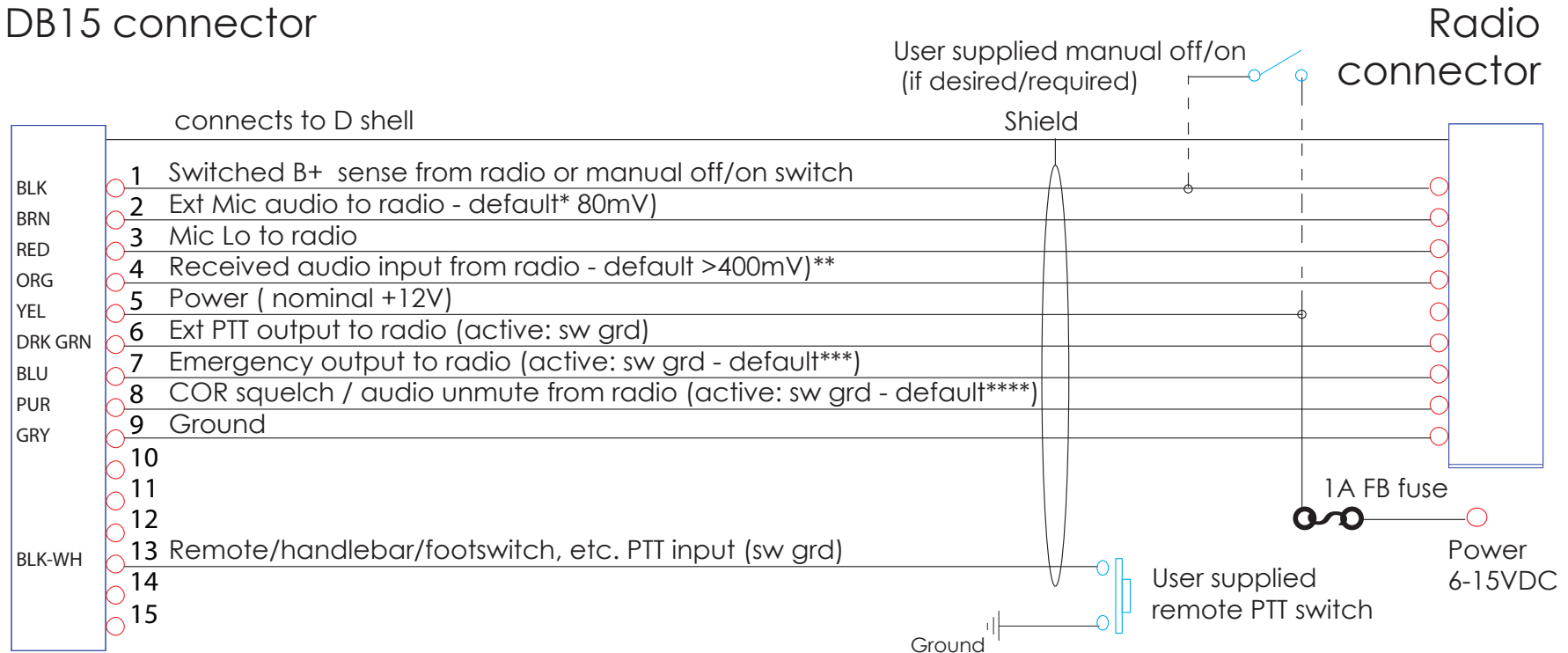

* Audio output to host mobile can be increased by programmer/via VR1 trim pot - use hole in base of mobile charger.

** Audio input from host mobile can be adjusted via VR2 trim pot - use hole in base of mobile charger.

*** Emergency output can be changed to "active high" by swapping solder jumpers SP1 & SP2.

**** COR/Squelch/unmute can be changed to "active high" by fitting solder jumper SP3.

NOTE: Pin 5 should be connected directly to battery to ensure charging when unit is turned off.

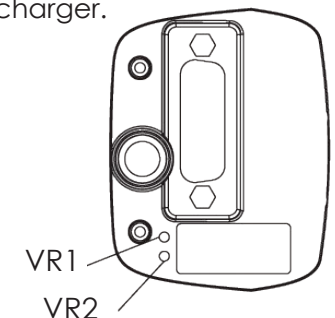

XMC-GEN Interface cable - Original generic cable version.

Note: different wiring colour scheme.
: for any mobile
V0

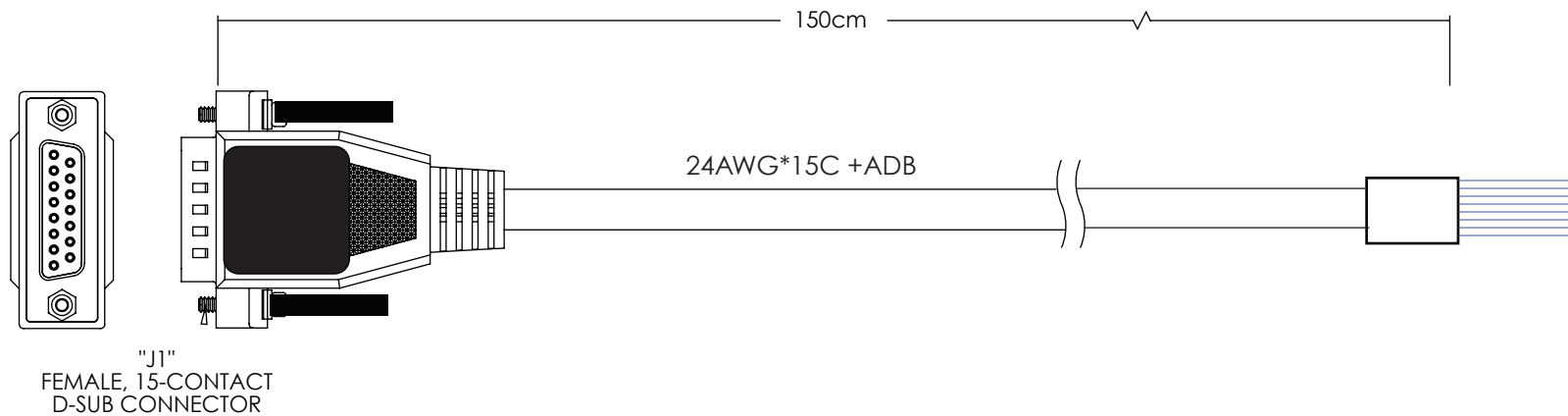
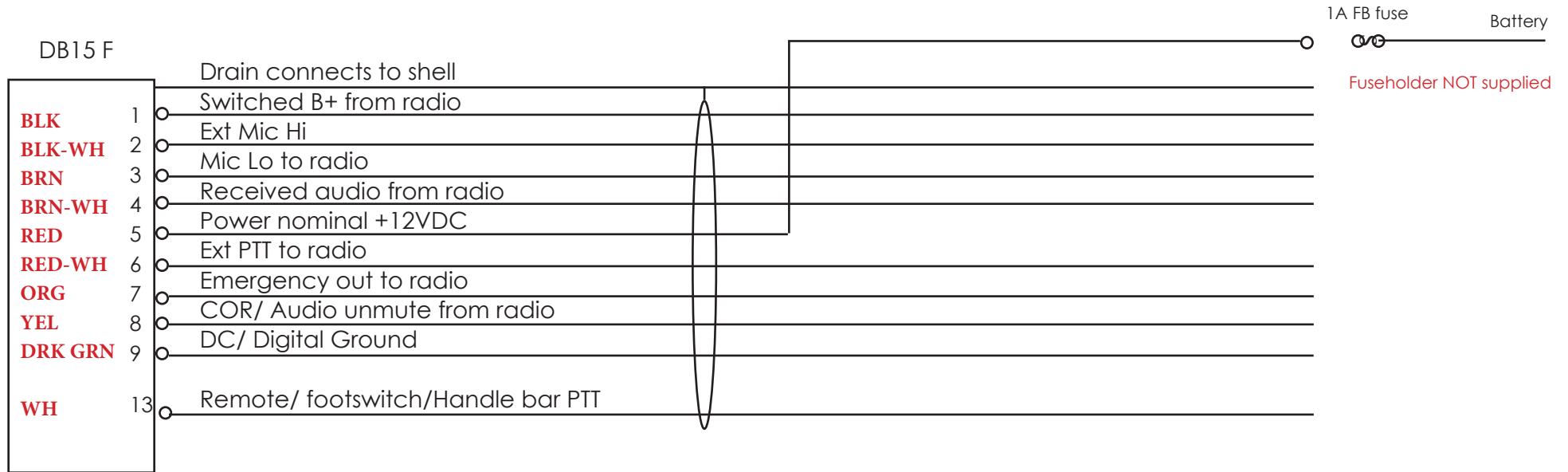

XMC-GEN Interface cable - Current version: for any mobile V1

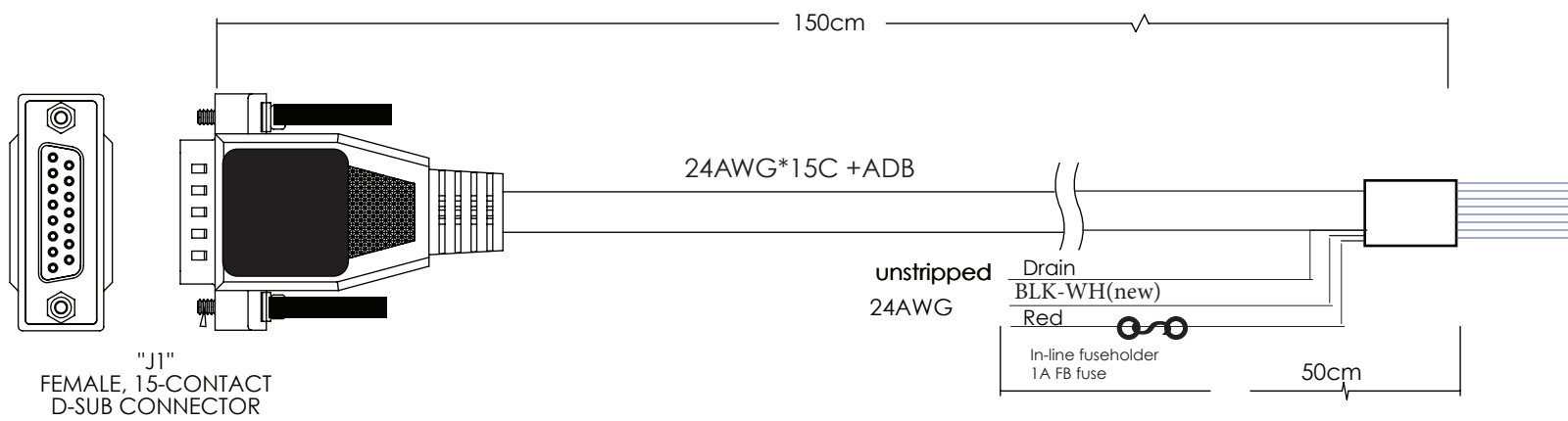
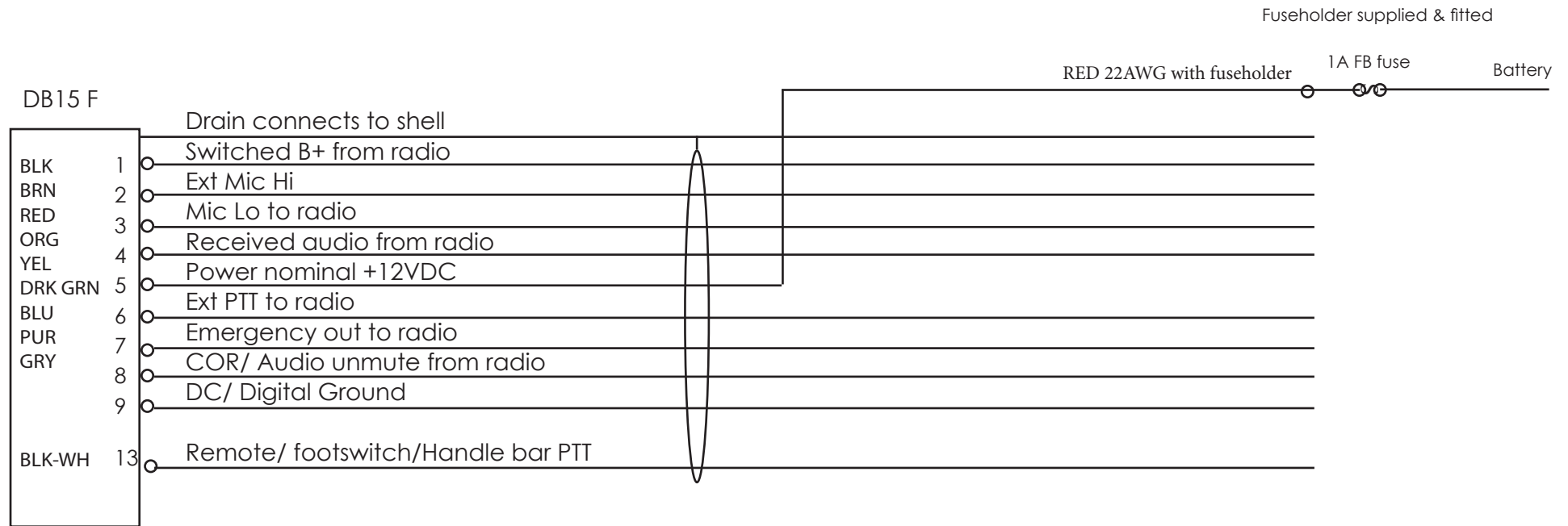

XMC-XTL Interface cable

: for Motorola APX/XTL series
V1

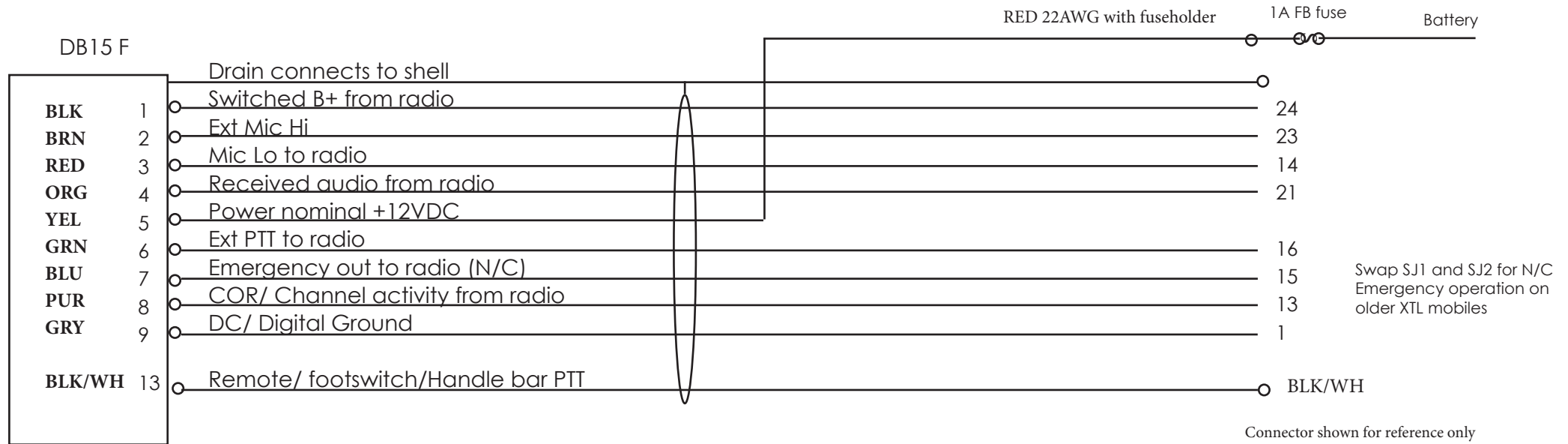

Connector shown for reference only
- not supplied with XMC-XTL cable

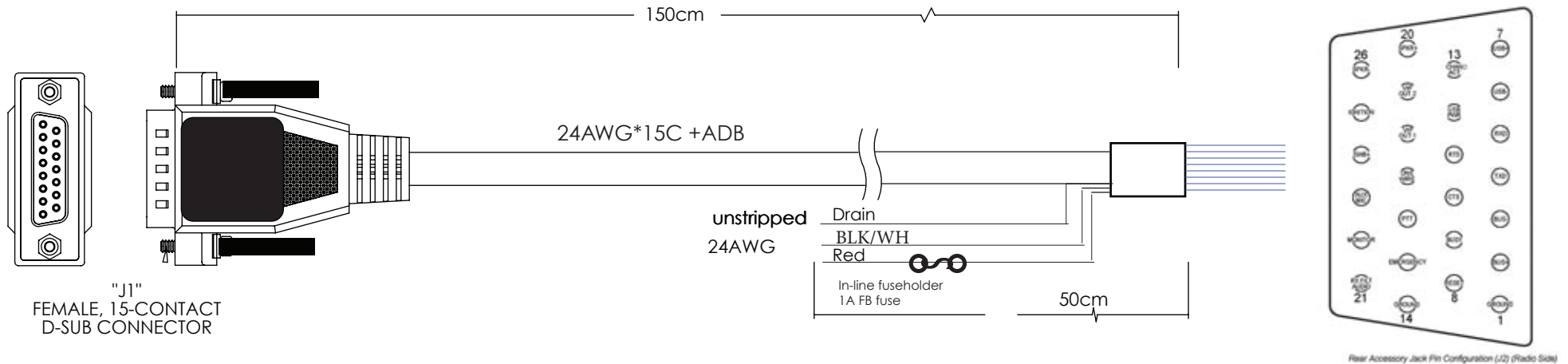

XMC-MCS Interface cable

: for Motorola MCS2000 models (with DB25 connector)
V0

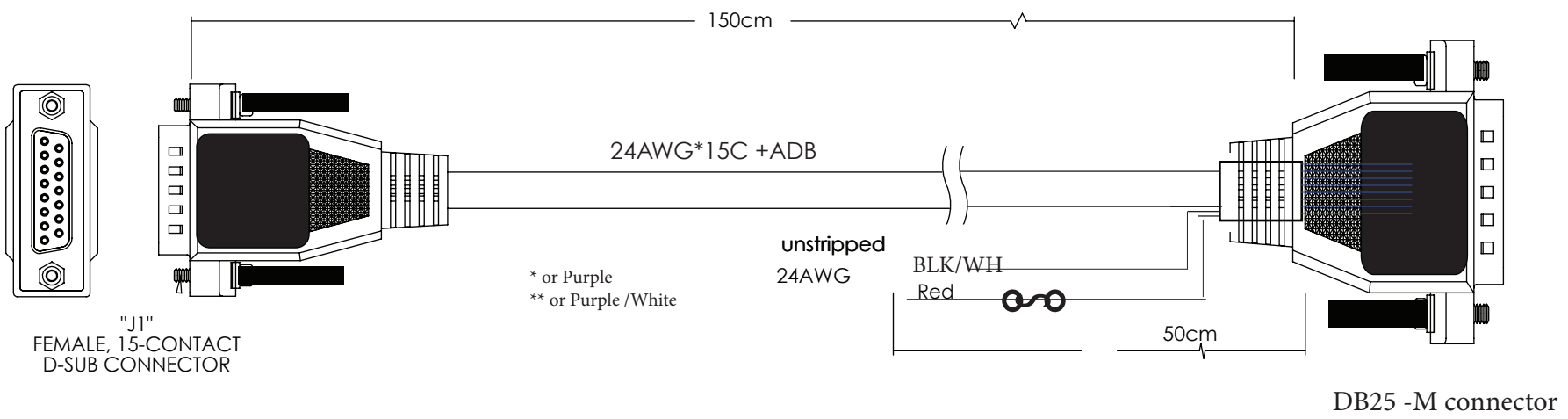
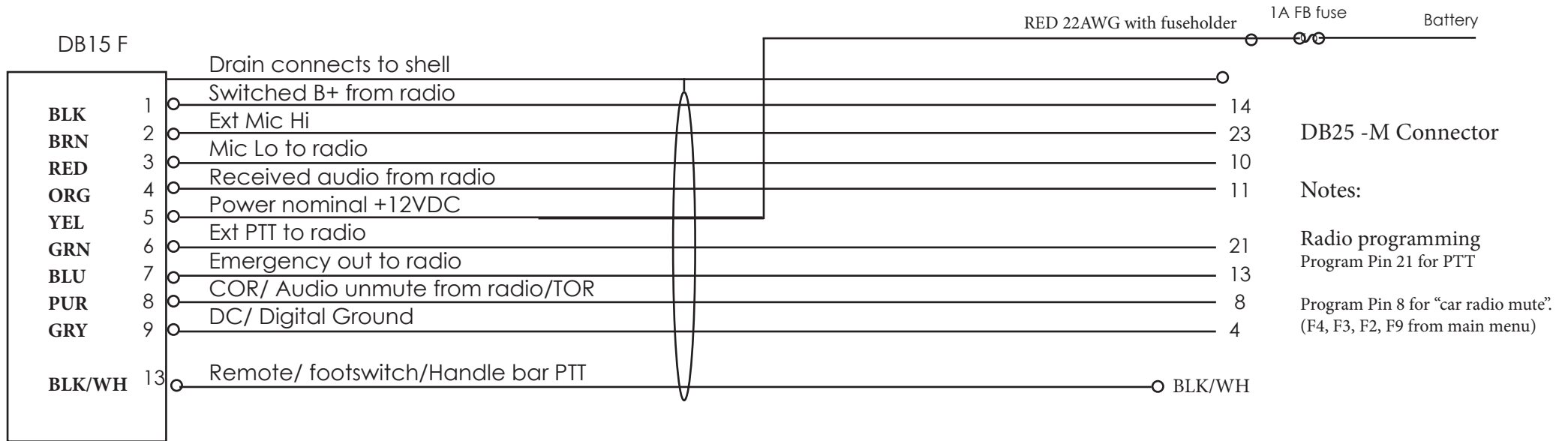

"J1"
FEMALE, 15-CONTACT
D-SUB CONNECTOR

* or Purple
** or Purple /White



XMC-M16 Interface cable

: for Motorola MTM800/GM360/MCX/PM400/CDM etc.

series

V0

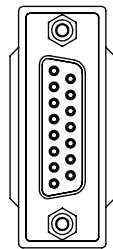
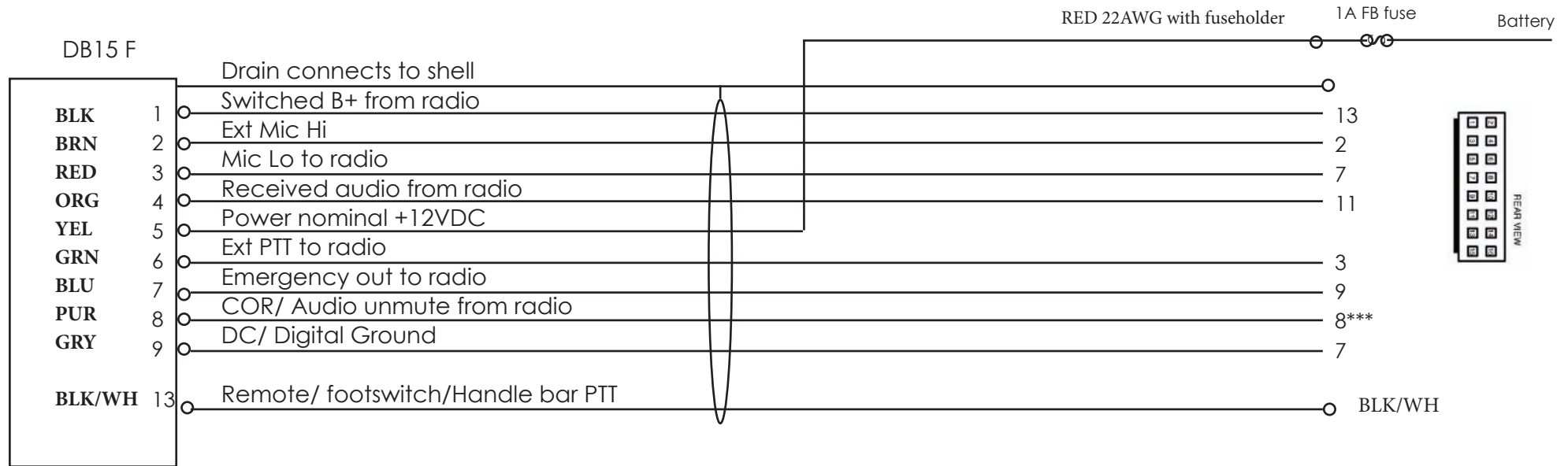

"J1"
FEMALE, 15-CONTACT
D-SUB CONNECTOR

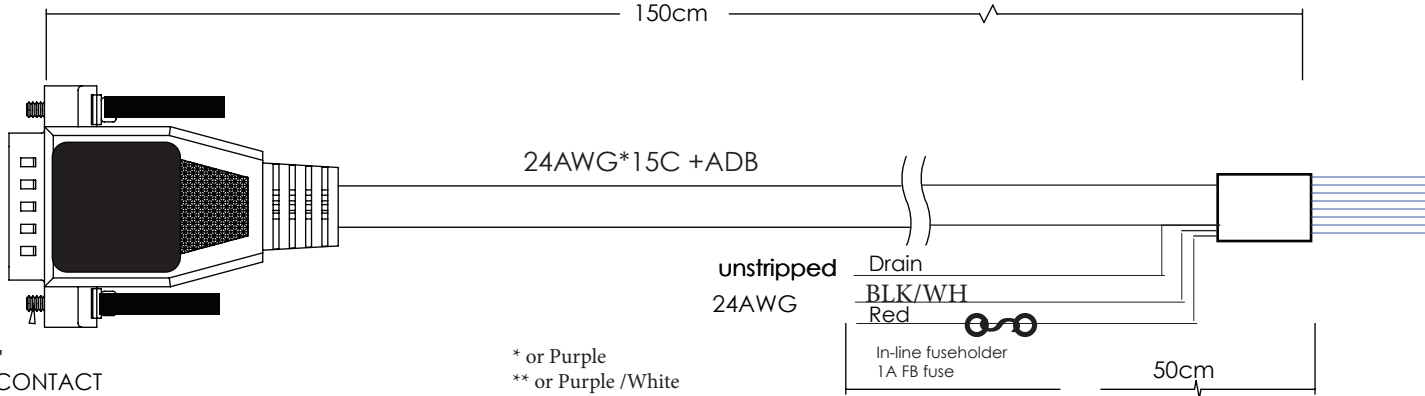

* or Purple
** or Purple /White

Note: Motorola have over the years used the 16 pin connector on a wide variety of models. You should check the radio programming and or jumpering to ensure correct operation of the X10DR unit.

***Pin 8 : may be programmable for COR depending on particular model.

Note: On MTM800 series TETRA radios Pin 8 - yellow wire MUST be removed from 16 pin connector and insulated.

Pin 9 may need programming for Emergency operation.

Pin 11: Should be set for pre-emphasis and gated where applicable by either programming or hardware jumper where applicable.

BEWARE: Consult GTX/LTS manual before attempting connection.



Company Confidential Proprietary

XMC-M25 Interface cable

: for Motorola PM1500 models (with DB25 connector)
V0



DB25 -M Connector

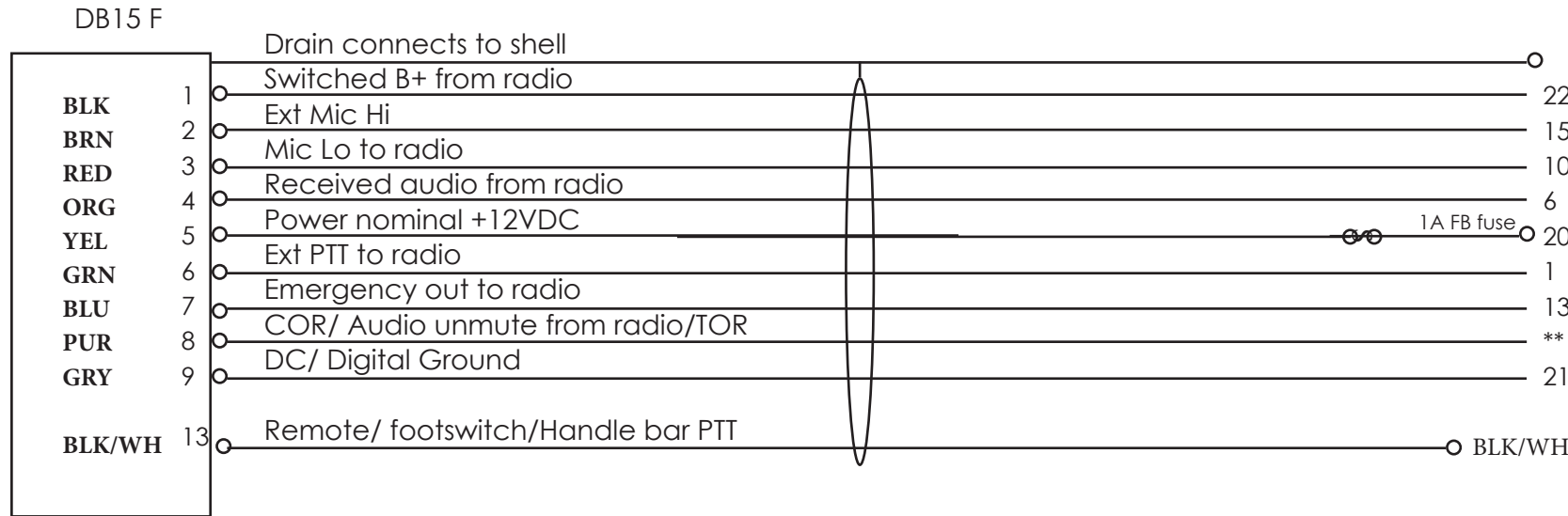

Notes:

Need to remove shorting jumper on radio TIB to enable Emergency function.

SJ1&2 may need to be swapped on X-ponder PCB if radio needs NC Emergency input. See X10DR user manual.

**PM1500 does not provide a COR output, so default operation of X10DR will be using Rx voice detect. (may cause some small voice clipping)

Alternatively, you may be able to re-configure internal jumpers on TIB to allow a switched ground indicate of "radio speaker unmute" to be applied to DB25 Pin 5 for COR.

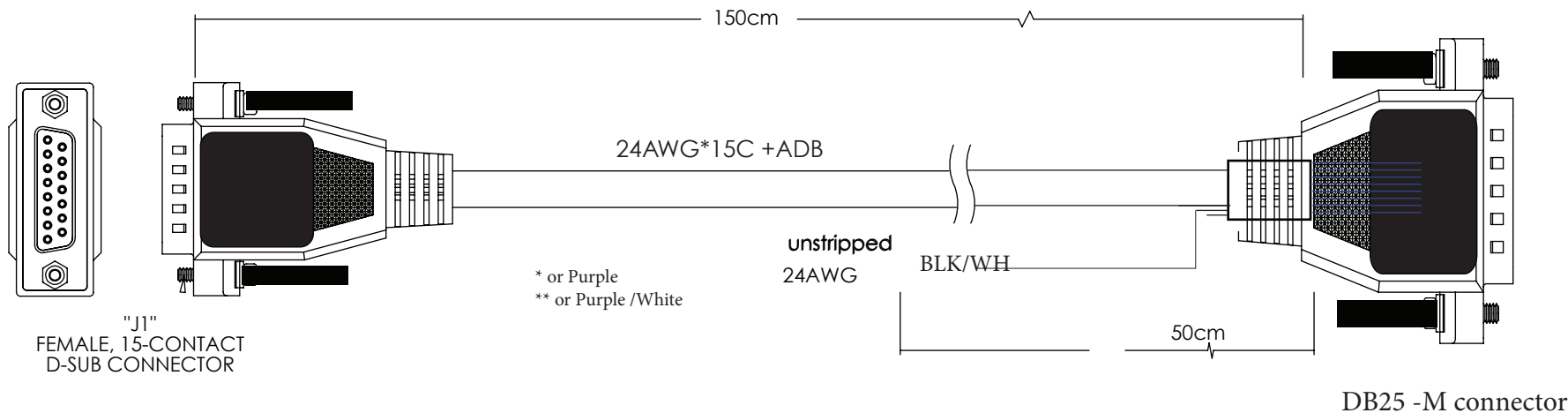

DB25 -M connector



XMC-M26T Interface cable

: for Motorola Tetra MTM5400 series
V1



(If you use XMC-M26 cable, you must move Mic Hi and Mic Lo

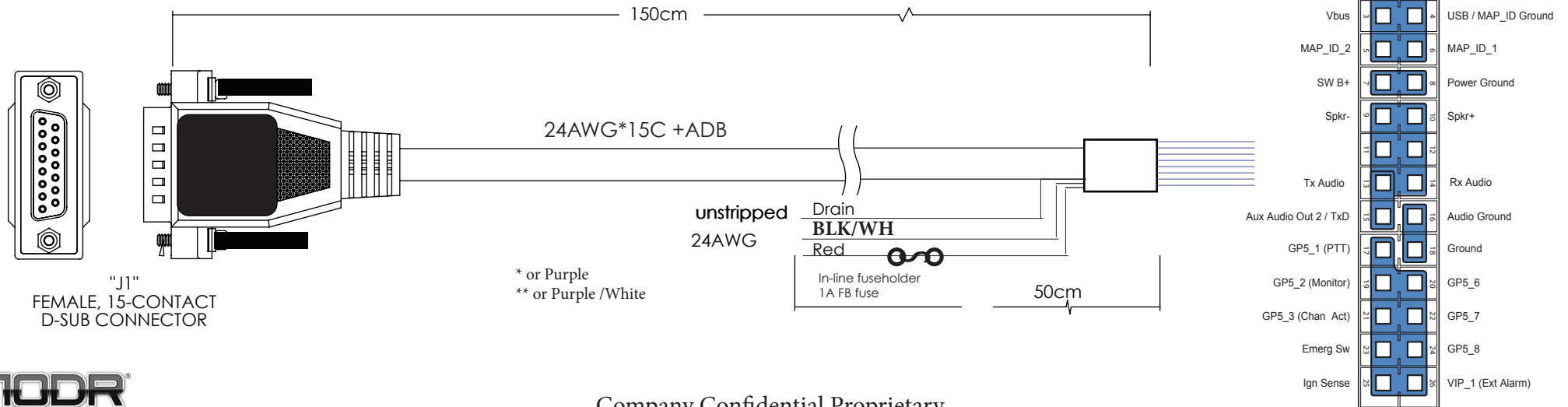
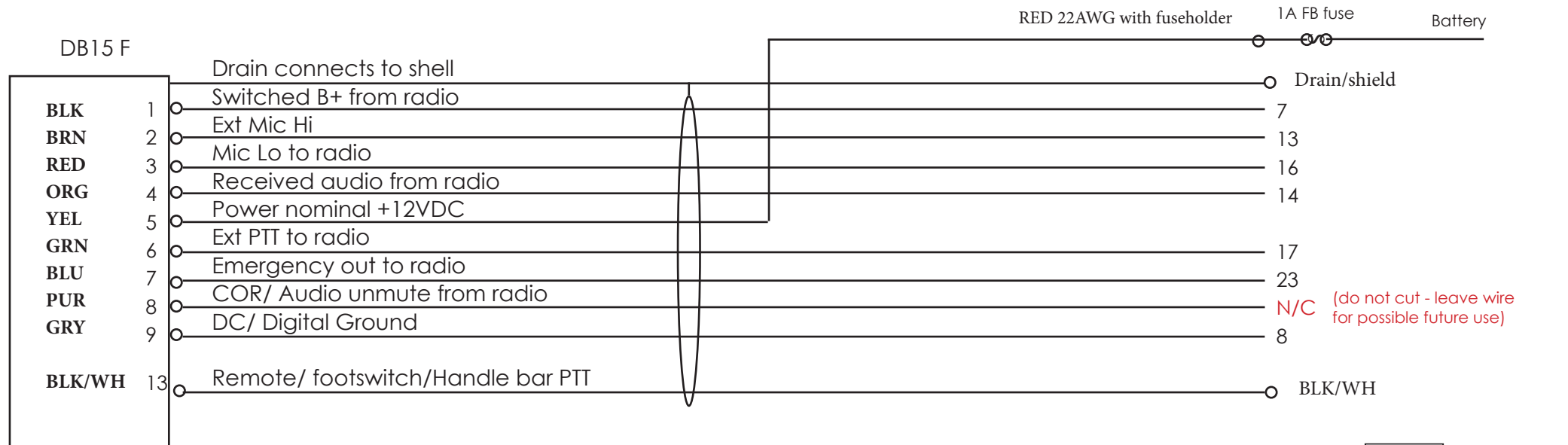

XMC-M26 Interface cable

: for Motorola Trbo XPR and DM3600 etc series

V0

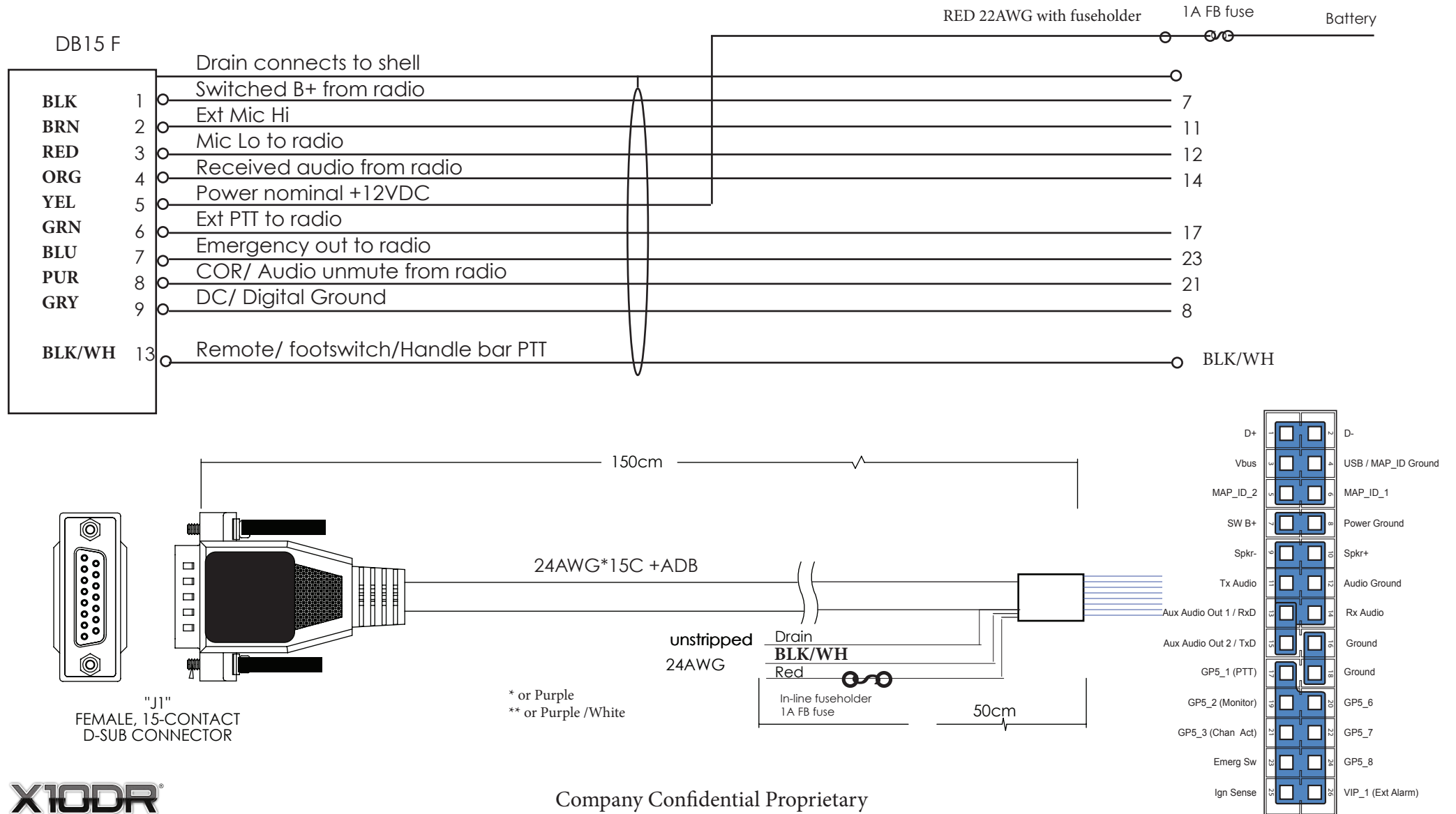

Company Confidential Proprietary

XPR/DM3600 Programming info v0

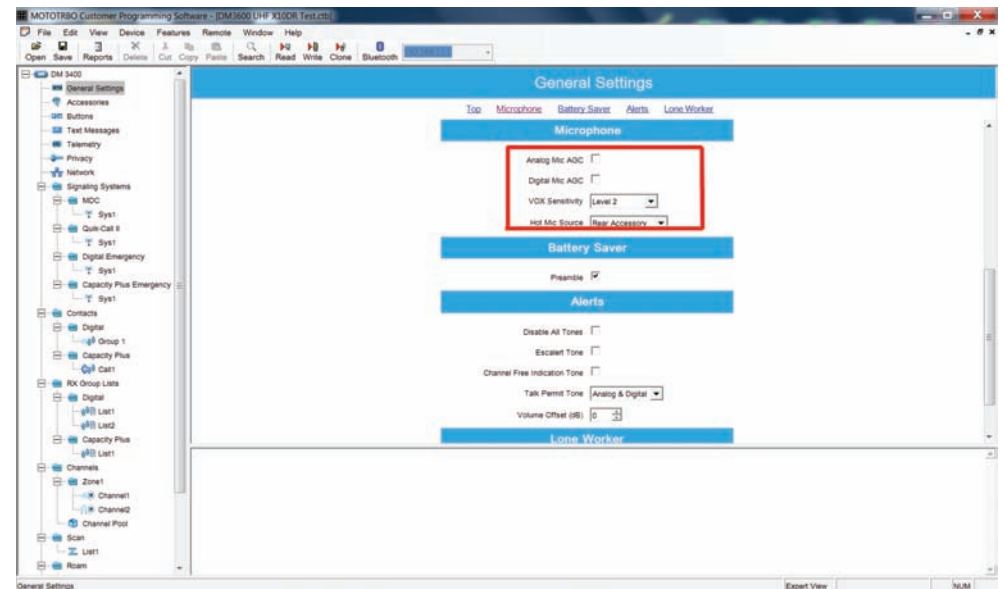
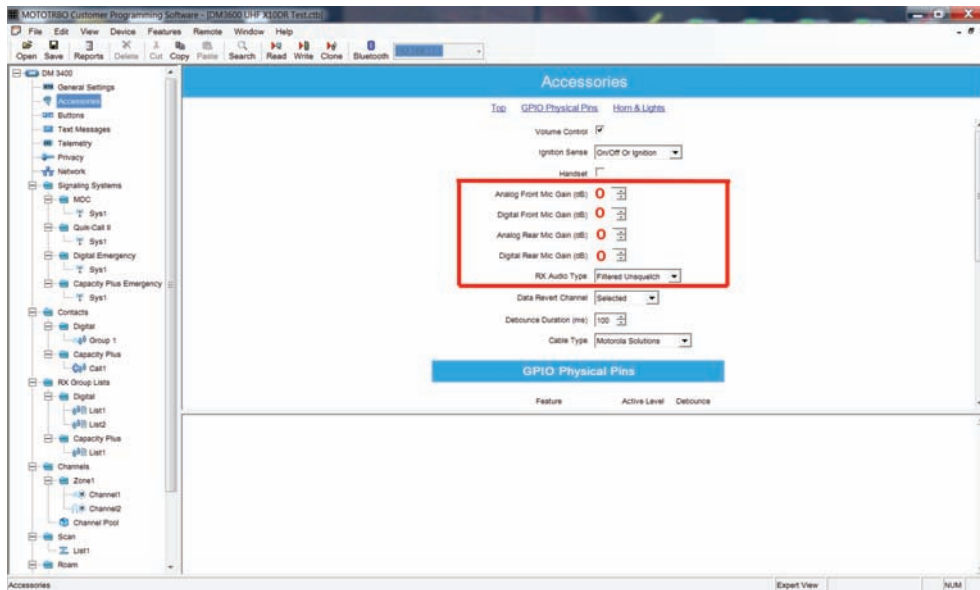
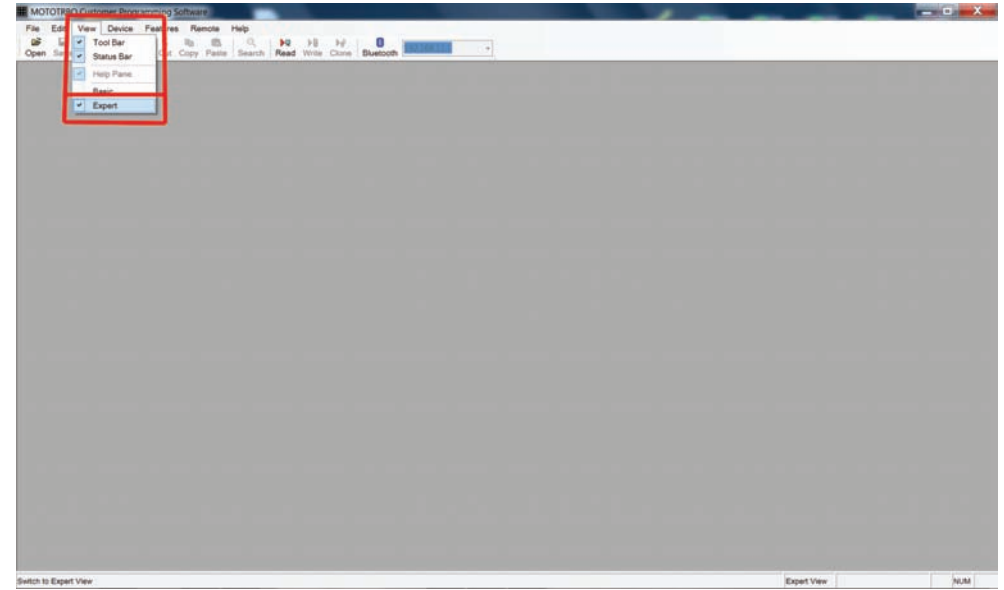
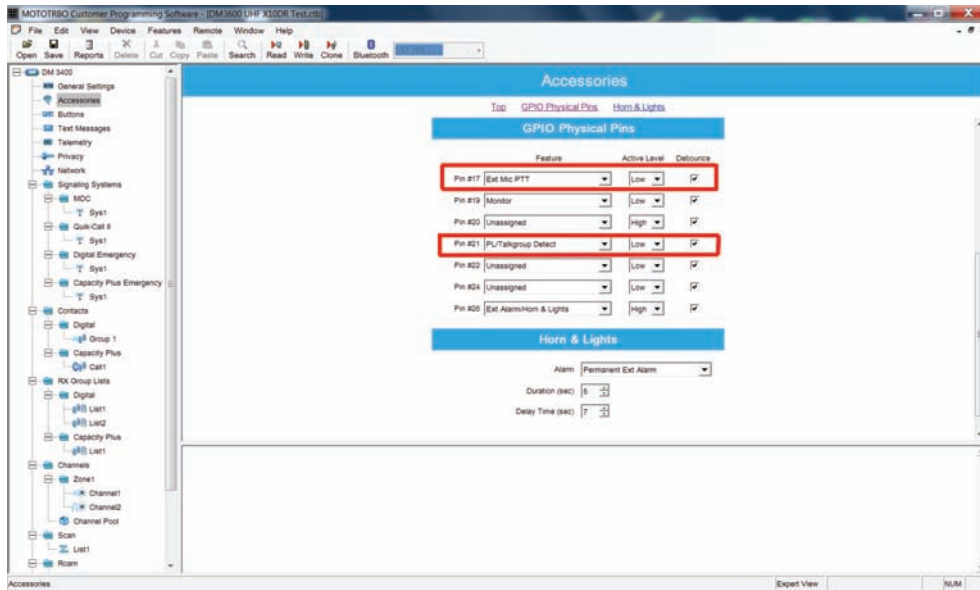

XMC-K25 Interface cable

: for Kenwood NX700/TK models (with DB25 connect)
V1

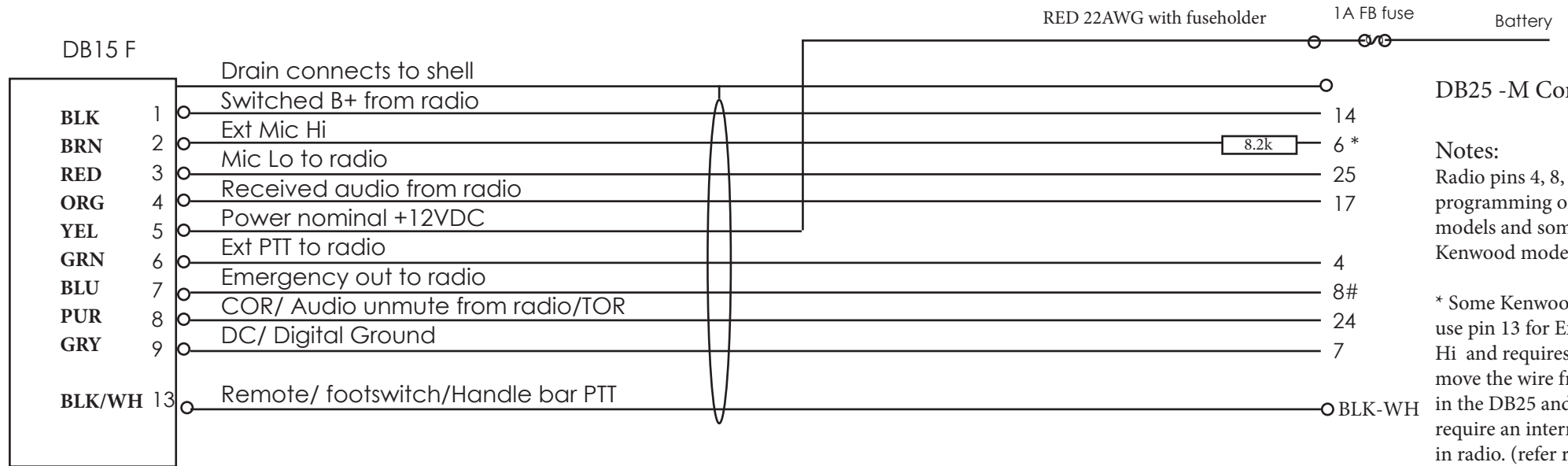

DB25 -M Connector

Notes:
Radio pins 4, 8, & 24 need programming on NX700 models and some other Kenwood models.

* Some Kenwood radios use pin 13 for External Mic Hi and requires you to move the wire from pin 6 in the DB25 and may also require an internal jumper in radio. (refer radio specific service manual)

Set external Mic sensitivity for "low" when available in the field programmer.

#May need to adjust Emergency TX time settings.

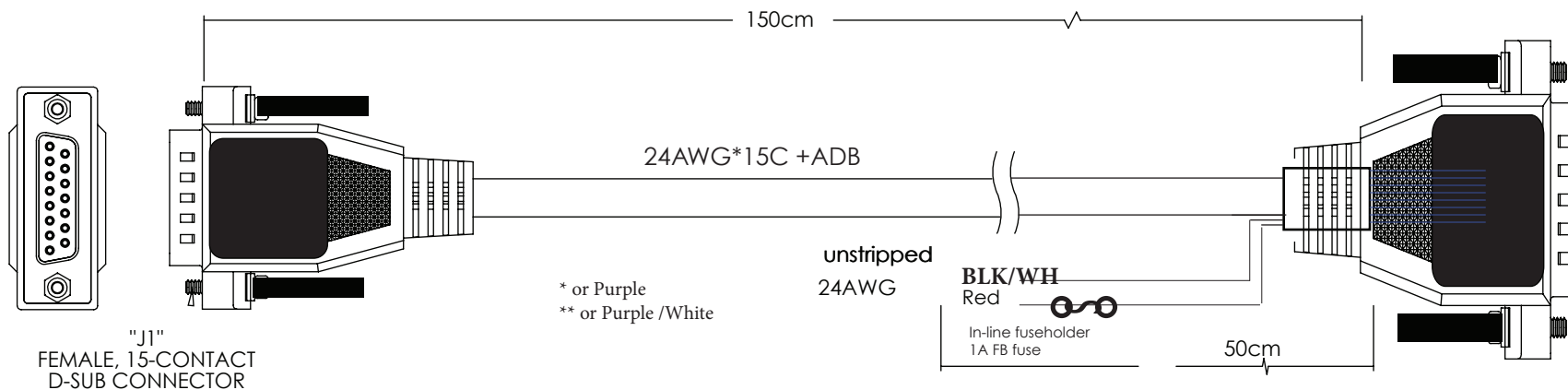

NX700/800 Programming info v0



KPG-111D [NX-800/800H/800HT] [Mobile: K UHF :450-520 MHz] [Data File :X10DR Demo Kenwood NX800K.dat] [Source File :kpg111d.sdt]

File Model Edit Program Tools Setup View Window Help

Zone Information [Zone -1 Channel -1]

Zone Type Signaling Type Zone Name

Extended Function

Pin number	I/O	Function	Active	Debounce
DB-25 4pin	Input	External PTT (Voice)	Low	Yes
DB-25 5pin	Input	Emergency	Low	Yes
DB-25 12pin	Input	None	Low	No
DB-25 13pin	Input	None	Low	No
DB-25 15pin	Output	None	Low	No
DB-25 16pin	Output	None	Low	No
DB-25 20pin	Output	None	Low	No
DB-25 21pin	Input	None	Low	No
DB-25 22pin	Output	None	Low	No
DB-25 23pin	Input	None	Low	No
DB-25 24pin	Output	TOR	Low	No

AUX Input: Data Dwell Time [s] 0, Mic Sense [0dB (Normal)], Debounce Time [ms] 10

AUX Output: LOK Logic Signal [Continuous], AUX Output Status Message, State Hold Timer (Active Low) [s] 0, Status Muting

KPG-111D [NX-800/800H/800HT] [Mobile: K UHF :450-520 MHz] [Data File :X10DR Demo Kenwood NX800K.dat] [Source File :kpg111d.sdt]

File Model Edit Program Tools Setup View Window Help

Zone Information [Zone -1 Channel -1]

Extended Function

PTT	Mic Line	M2 Line	DI Line	With QT/DQT	With STE
Mic PTT	Connect	Disconnect	Disconnect	Yes	Yes
External PTT (Voice)	Disconnect	Connect	Disconnect	Yes	Yes
External PTT (Data)	Disconnect	Disconnect	Connect	Yes	Yes
Data PTT	Disconnect	Disconnect	Connect	Yes	Yes

Modulation Line by Mic PTT

KPG-111D

Contents Index Search

Type in the keyboard to find

Mic Sense (AUX Input)

Mic Sense allows you to configure the level of microphone sensitivity (Mic Line and M2 Line) when External PTT (Voice), External PTT (Data), or Data PTT is activated.

The appropriate level of microphone sensitivity for normal operations is 0 dB, and a parameter for Microphone Sense can be configured based on this level.

Range:

6dB, 4dB (High), 2dB, 0dB (Normal), -2dB, -4dB, -6dB, -8dB, -10dB (Low), -12dB, -14dB, -16dB, -18dB or -20dB

Default:

0dB (Normal)

Note:

- M2 Line is available from pin number 6 of DB-25 connector (female) on the rear panel.
- Configuring the value lower than 0 dB for Mic Sense also reduces the amplitude limit level, hence, level for Modulation Limiting (minimum) will be reduced in the Analog FM mode.
- 10dB (Low) can be configured for a transceiver having firmware version 1.11 or later. A transceiver having firmware version earlier than 1.11 can behave in the same manner as if 0dB (Normal) is configured for the microphone sensitivity.
- The value other than 4dB (High), 0dB (Normal) and -10dB (Low) can be configured for a transceiver having firmware version 2.50 or later. A transceiver having firmware version earlier than 2.50 can behave in the same manner as if 0dB (Normal) is configured for the microphone sensitivity.

Available Models with this Function

Model Name	Availability of this Function
NX-200/ NX-300	
NX-200S/ NX-300S	
NX-700/ NX-700H	V
NX-800/ NX-800H	

KPG-111D [NX-800/800H/800HT] [Mobile: K UHF :450-520 MHz] [Data File :X10DR Demo Kenwood NX800K.dat] [Source File :kpg111d.sdt]

File Model Edit Program Tools Setup View Window Help

Zone Information [Zone -1 Channel -1]

Extended Function

Optional Board | AUX | Remote Zone-CH/GD | Modulation Line | Mobile Function

DI Level: -1, DEQ Level: +4

XMC-K15 Interface cable

: for Kenwood 15 Pin radios/ **KCT-19** cable
V0

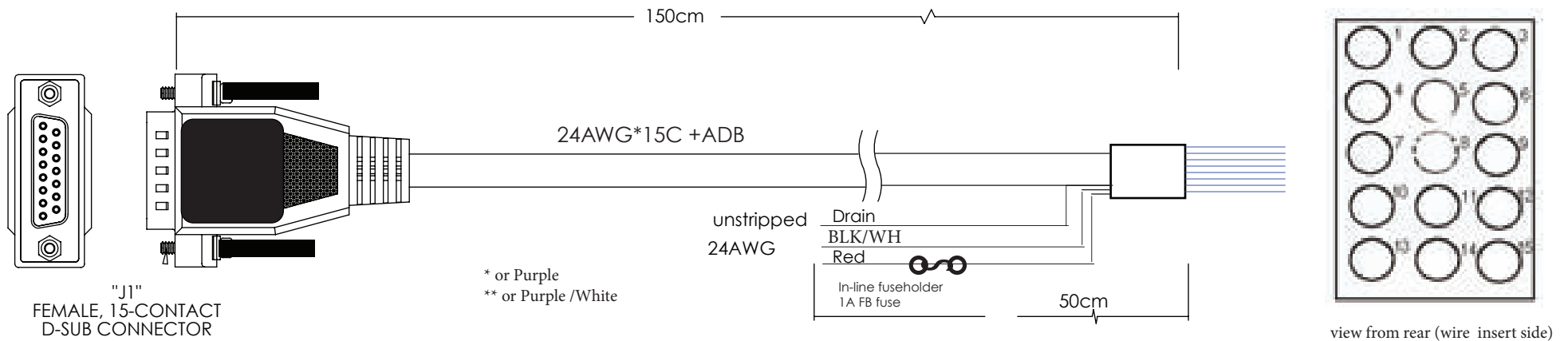
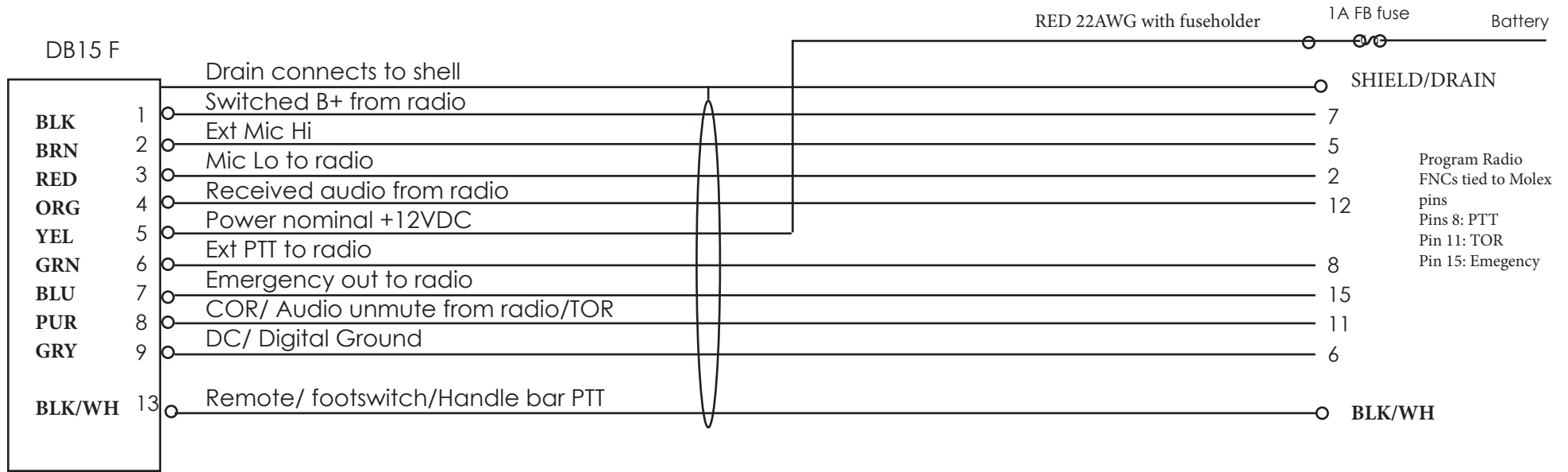

XMC-K15D Interface cable

: for Kenwood DB15 cable NX720 and TK8360
V0

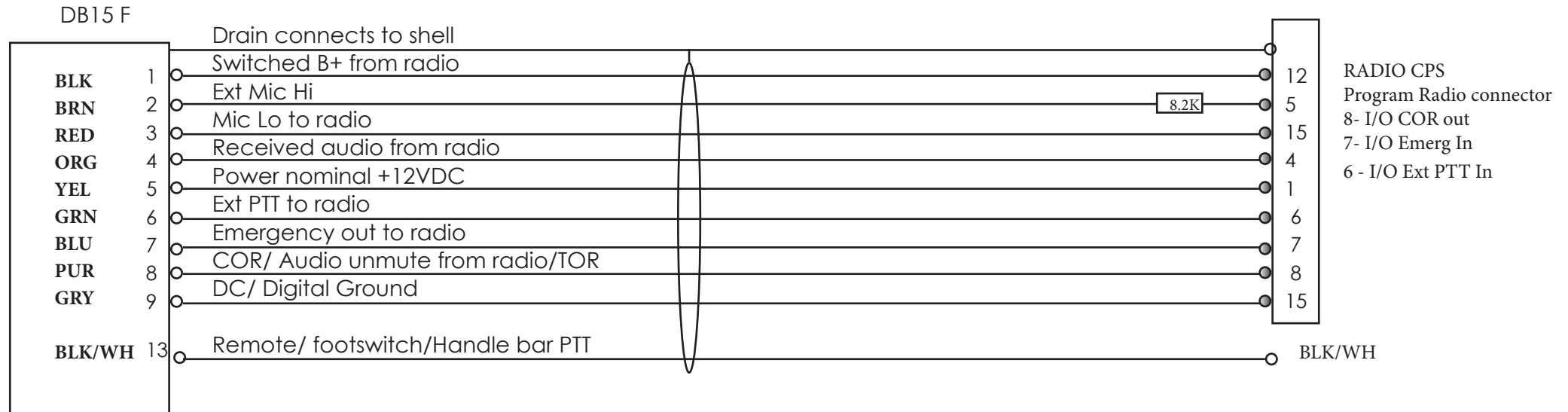

NX720
Move chip jumper R796 to R798
Move chip jumper R797 to R799

TK8360
Requires VOX to be disabled on X10DR cradle : SJ4 out.
A short burst of noise will sound sometimes when pressing PTT. This is because the Rx audio from the TK radio is not muted. Alternatively the radio must be modified so the pin 4 of the db15 connector connects to the junction R790/ pin 10 of IC706

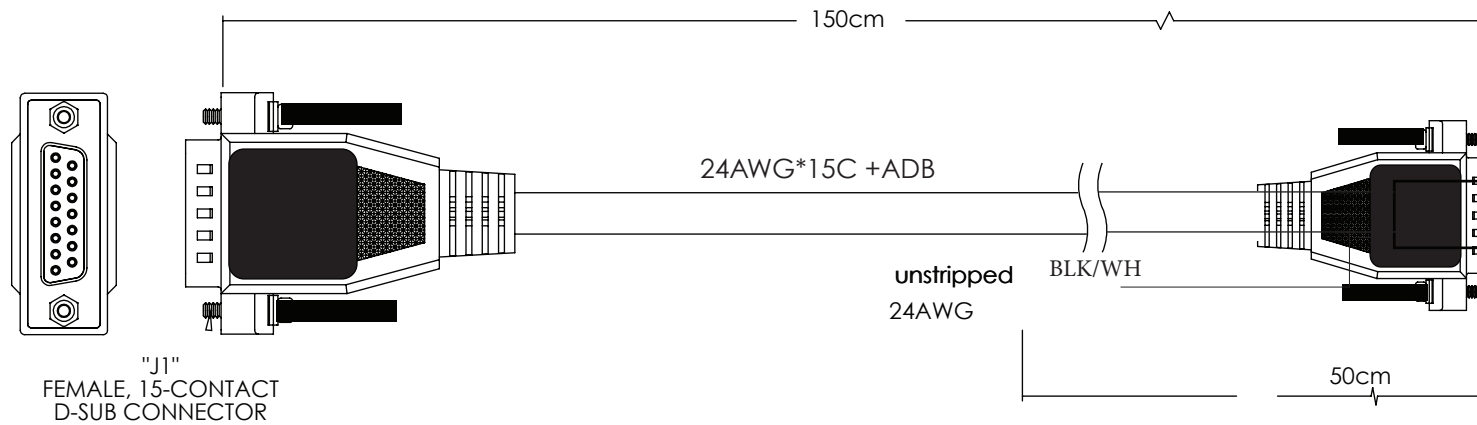

DB15P D-SUB CONNECTOR



XMC-K15 Interface cable

: for Kenwood 15 Pin radios using **KCT-39** cable/TK7160 etc
V0



NOTE: The XMC-K15 Cable is factory set up for KCT-19 Kenwood interface cable.

To use with KCT-39 you must rewire the XMC-K15 molex 15 pin connector as per the following:

Additionally, you **must** move two wires in connector CN3 of Kenwood's KCT-39 cable. (see insert)

Note: X10DR must be set for 200mV mic audio out (pin2) - may require use of XPK programmer.

Note: TK7160 is only capable of providing carrier squelched Rx audio which means if others are sharing the channel on different CTCSS codes will be heard unless VOX is disabled in X-ponder unit (see page 4).

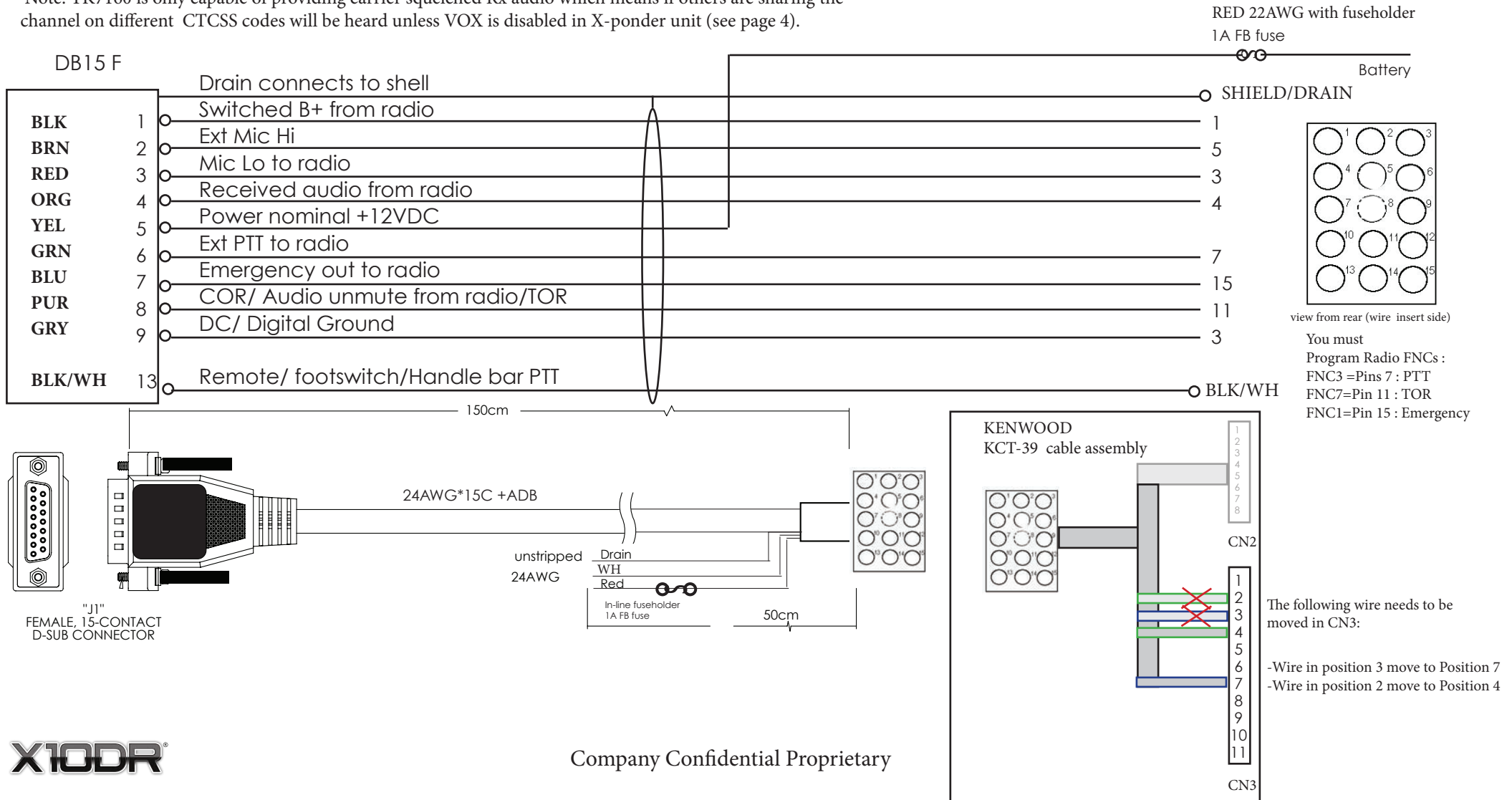

Company Confidential Proprietary

XMC-K15S Interface cable

: for Kenwood DB15 cable TK7360/8360 (alternate config)

V0 : requires use of external speaker

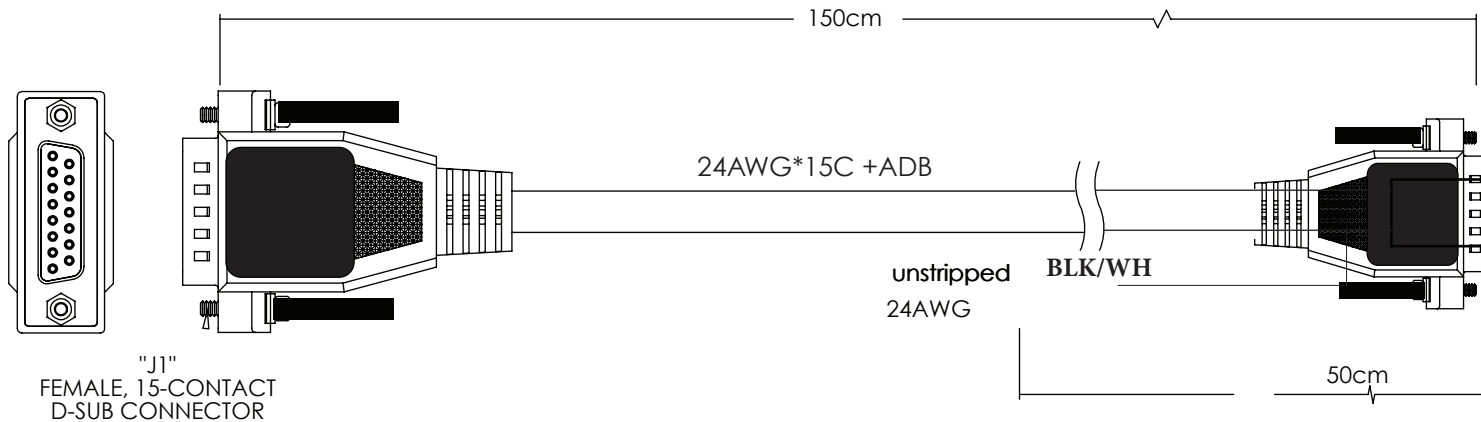
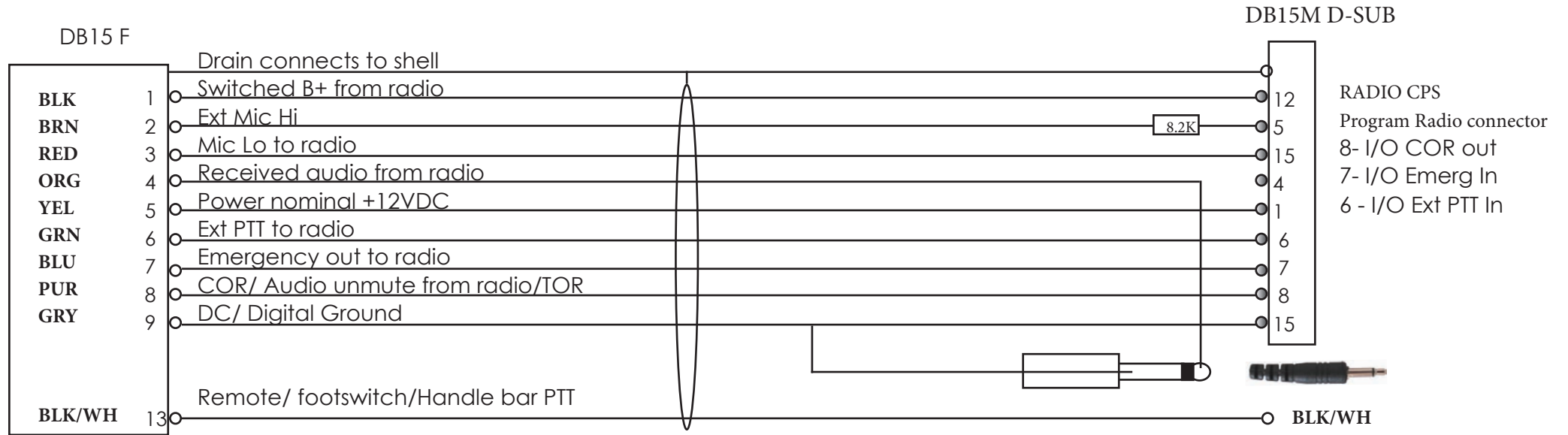

TK8360

Plug dual 3.5 "Y" adaptor into radio spk socket. Plug 3.5 plug from XMC into one 3.5 jack. Plug radio external spk into other 3.5 jack. Set Radio volume control for normal listening level, then adjust VR2 on X-ponder cradle for desired listening level from X10DR Spk Mic.

Y adaptor sourcing:
<http://www.amazon.com/Headphone-Splitter-Stereo-3-5mm-Adapter/dp/B0002ZPK4O> or similar. (can be mono)



XMC-T15 Interface cable

: for Tait TM/7000/8000/9000 Series
V0

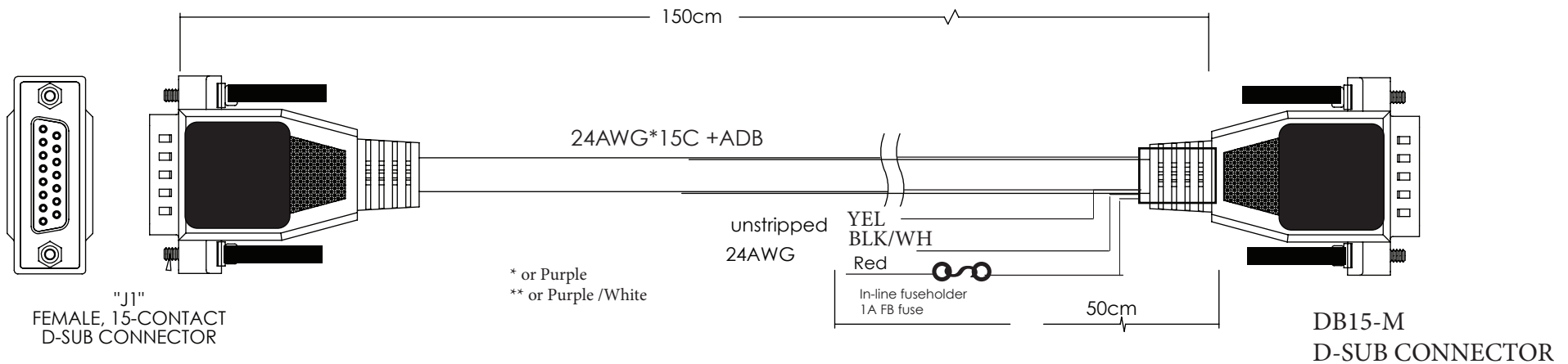
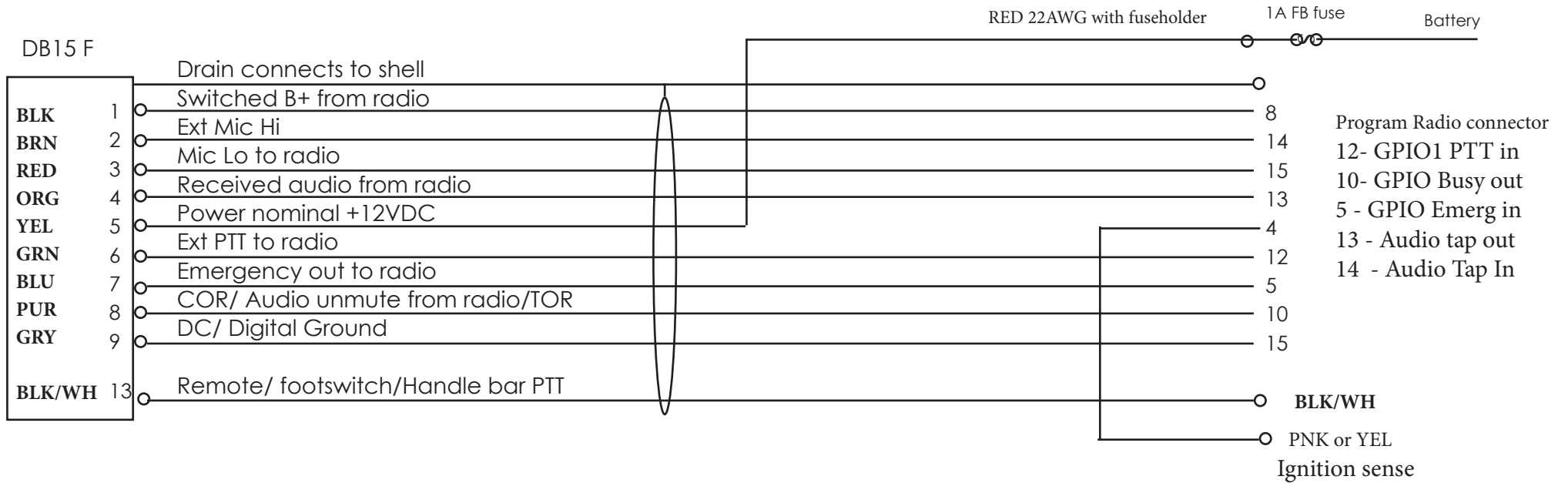

TM9000 Programming info V0



Programmable I/O

Digital | Audio | Channel Selection

Pin	Direction	Label	Action	Active	Debounce	Signal State	Mirrored To
AUX_GPI1	Input	PIN_12	External PTT 1	Low	10	None	None
AUX_GPI2	Input	PIN_5	Enter Emergency Mode	Low	10	None	None
AUX_GPI3	None	PIN_4	No Action	None	None	None	None
AUX_GPIO4	Output	PIN_10	Signaling Audio Mute Stati	Low	None	None	None
AUX_GPIO5	Input	PIN_2	Send Mic Audio To Spkr	Low	10	None	None
AUX_GPIO6	None	PIN_9	No Action	None	None	None	None
AUX_GPIO7	None	PIN_1	No Action	None	None	None	None
IOP_GPIO1	None	PIN_9	No Action	None	None	None	None
IOP_GPIO2	None	PIN_10	No Action	None	None	None	None
IOP_GPIO3	None	PIN_11	No Action	None	None	None	None
IOP_GPIO4	None	PIN_12	No Action	None	None	None	None
IOP_GPIO5	None	PIN_13	No Action	None	None	None	None
IOP_GPIO6	None	PIN_14	No Action	None	None	None	None
IOP_GPIO7	None	PIN_15	No Action	None	None	None	None
CH_GPIO1	None	C_HEAD	No Action	None	None	None	None

Programmable I/O

Digital | Audio | Channel Selection

Px/PTT Type	Tap In	Tap In Type	Tap In Unmute	Tap Out	Tap Out Type	Tap Out Unmute
Px	None	A-Bypass In	On PTT	R10	D-Split	Speaker Unmuted
Mic PTT	None	A-Bypass In	On PTT	T3	D-Split	On PTT
EPTT1	R10	A-Bypass In	On PTT	None	C-Bypass O	On PTT
EPTT2	None	A-Bypass In	On PTT	None	C-Bypass O	On PTT

PTT

Mic PTT [External PTT (1)] External PTT (2)

EPTT1 Call Initiation end Monitor

PTT Monitor [Never]

De-key Alter PTT Monitor

EPTT1 Inhibit

Inhibit PTT When Emergency Active

Inhibit PTT Transmission When Mic on Hook

Inhibit PTT When External PTT Inhibit Active

Indicate PTT Inhibit to User

Advanced EPTT1

PTT Transmission Type [Voice]

PTT State is Reflected

PTT Priority [Medium]

Audio Source [Aux Mic]

XMC-i15 Interface cable

: for Icom OPC-1939 adaptor cable
V1

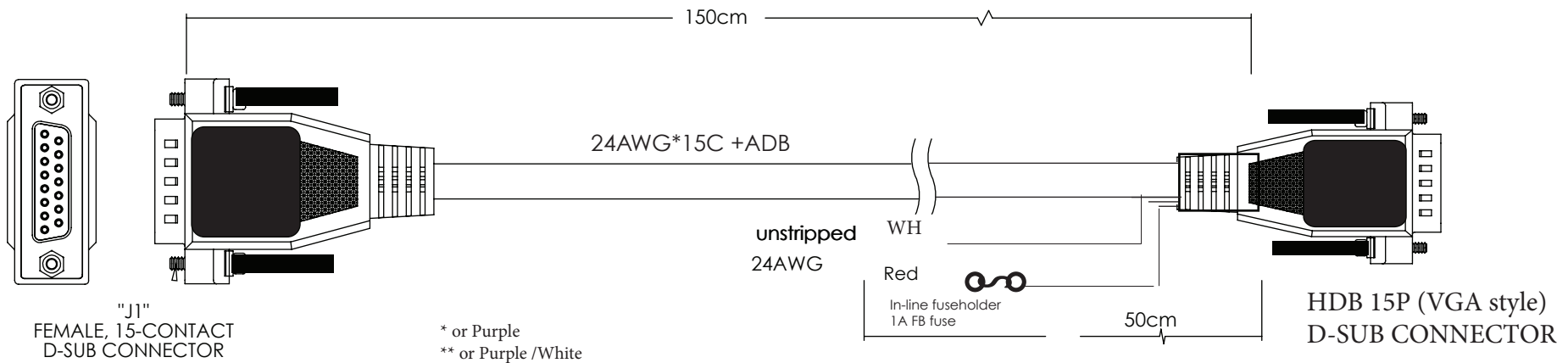
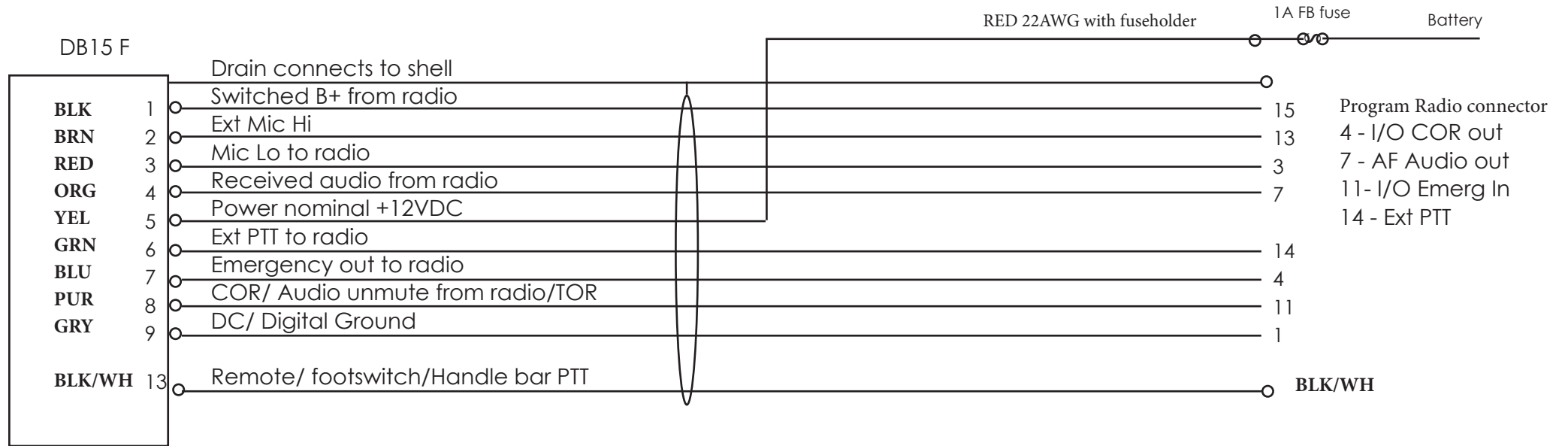

XMC-i25 Interface cable

: for Icom IC-F5061/9511 etc
V1

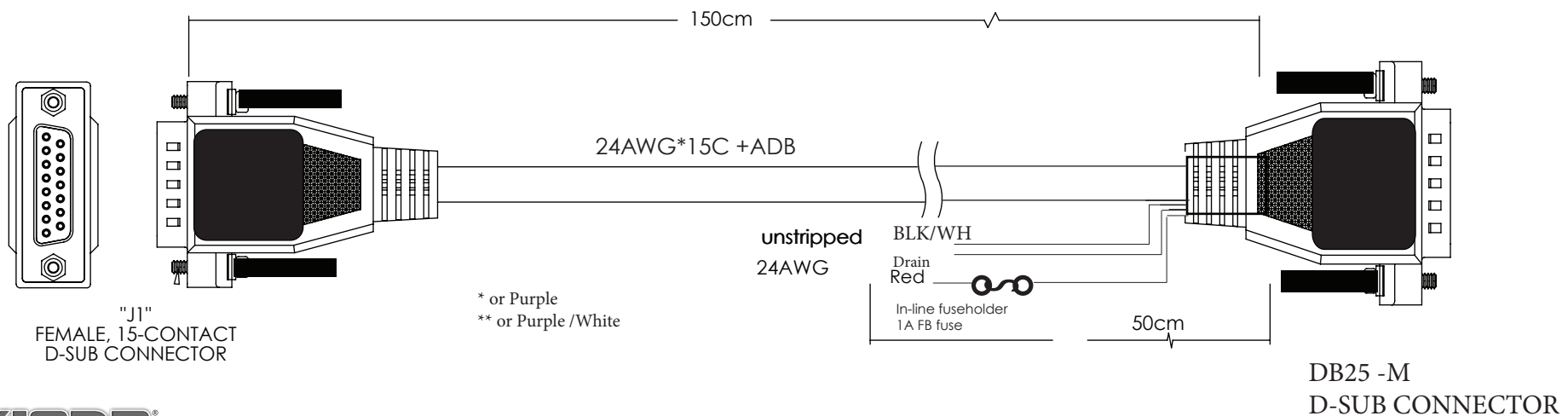
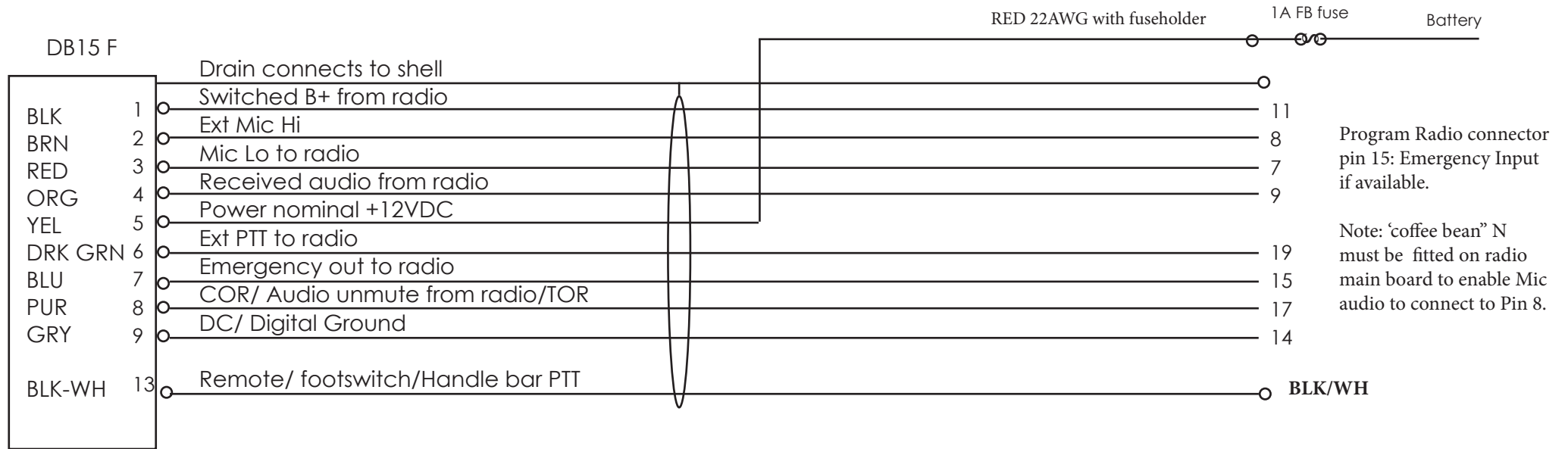

* or Purple
** or Purple /White

XMC-HXG Interface cable

: for Harris XG100 High tier mobiles
V1

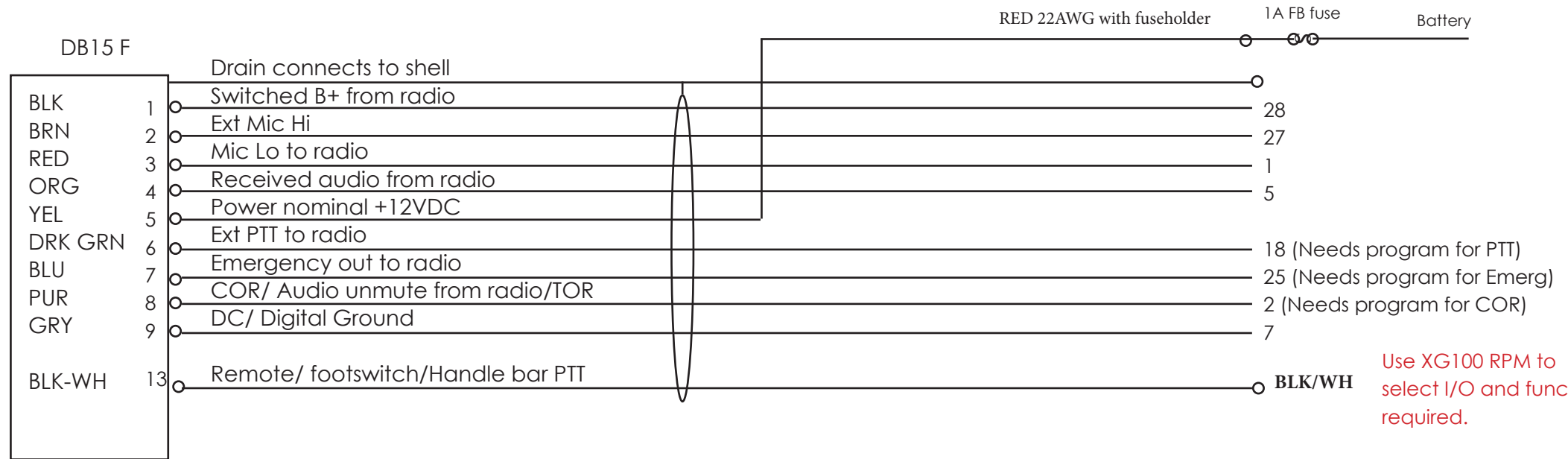

Use XG100 RPM to select I/O and function required.

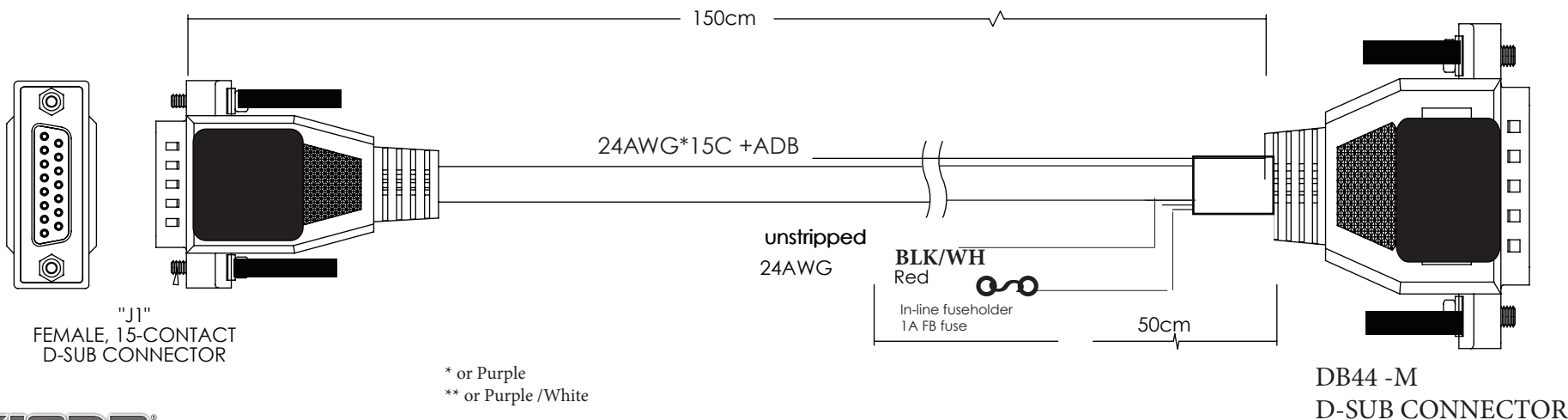

* or Purple
** or Purple /White



Company Confidential Proprietary

XMC-V25 Interface cable

: for Vertex VX5500 etc High tier mobiles
V0

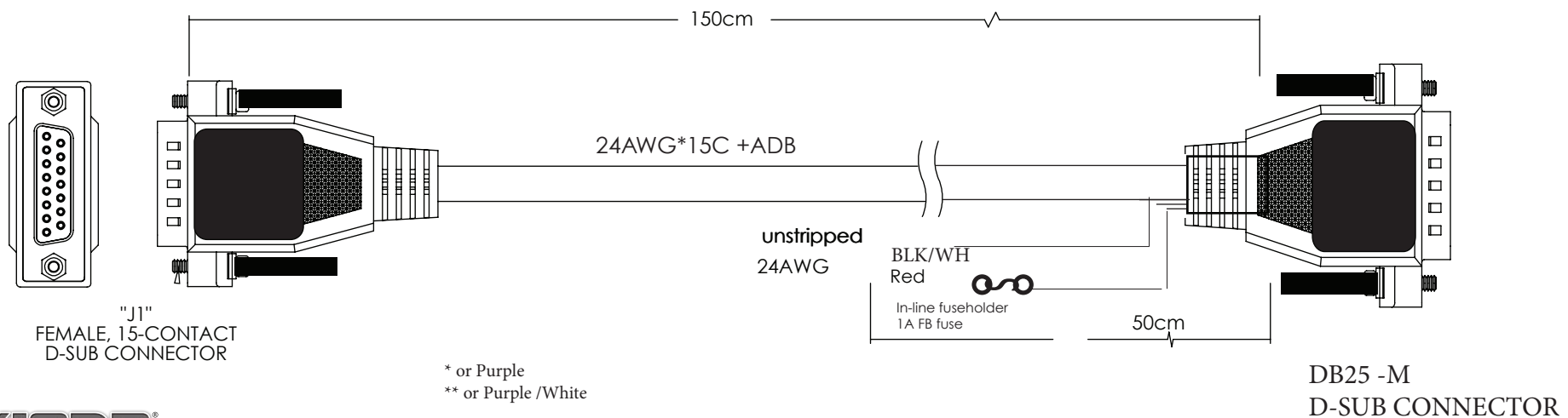
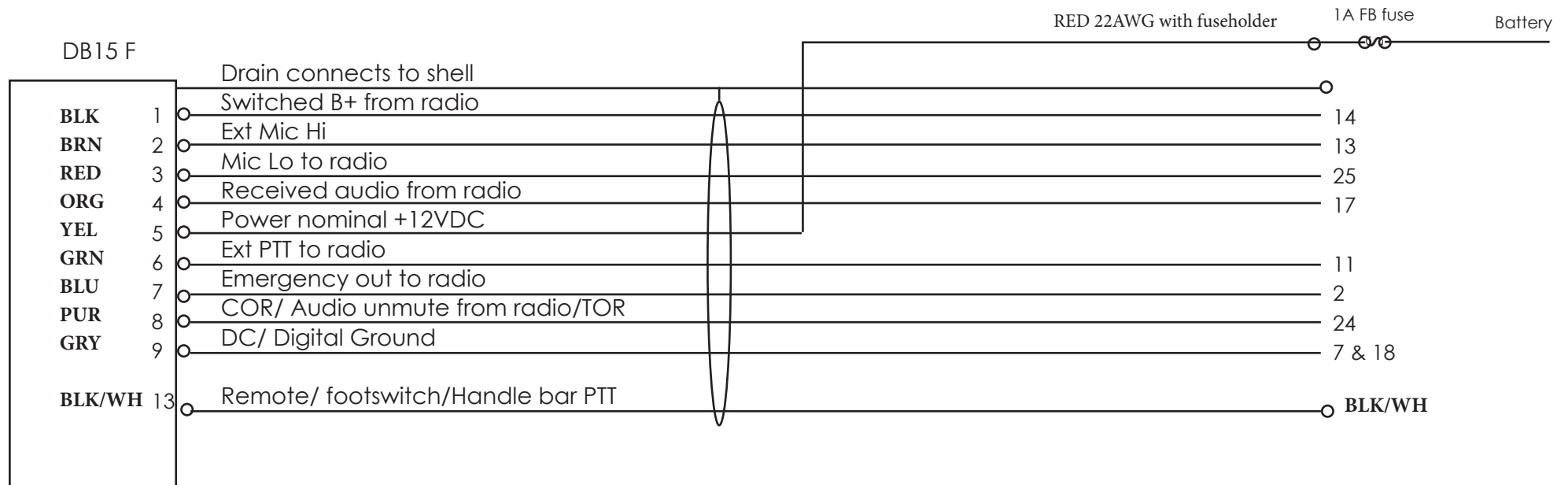

XMC-V15 Interface cable

: for Vertex 15 pin lower tier mobiles
V0

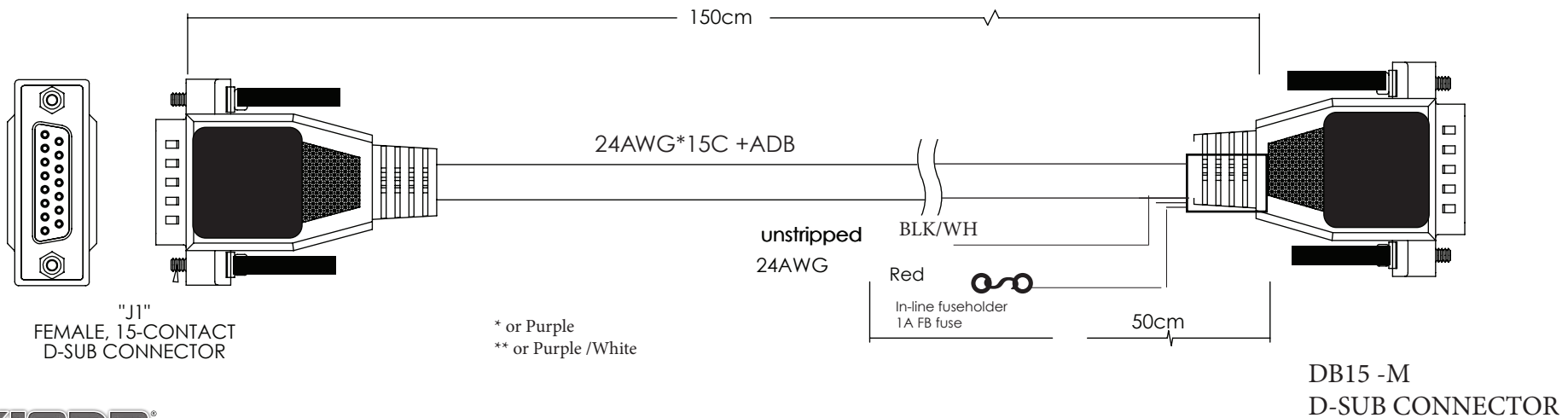
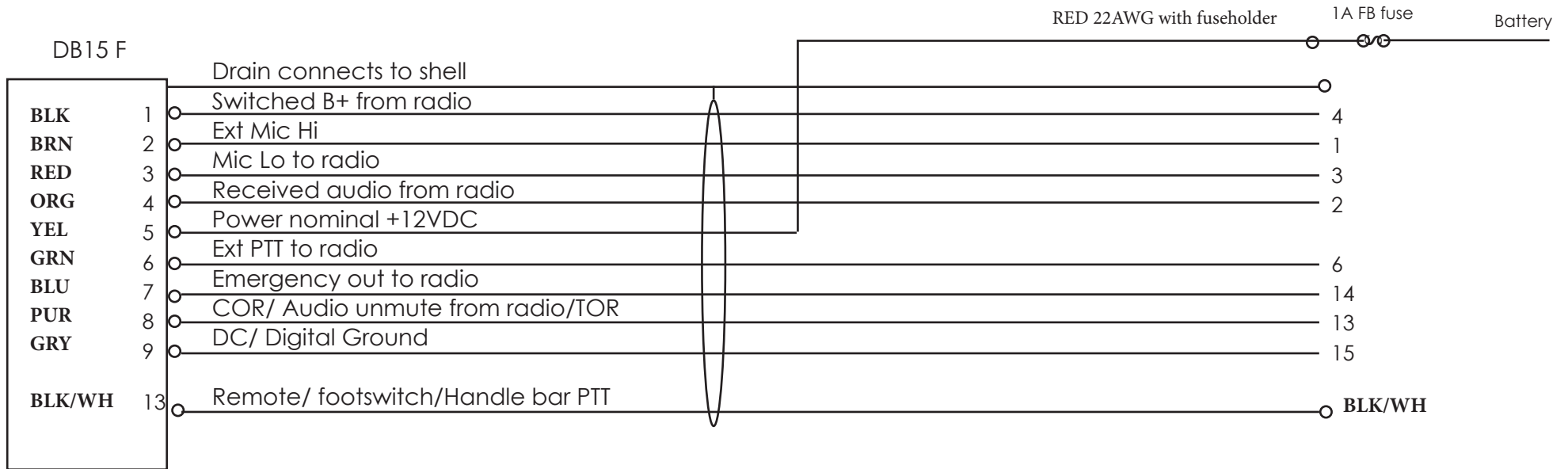

Company Confidential Proprietary

XMC-C26 Interface cable

: for Cassidian TMR880/i mobiles
V1



DB15 F

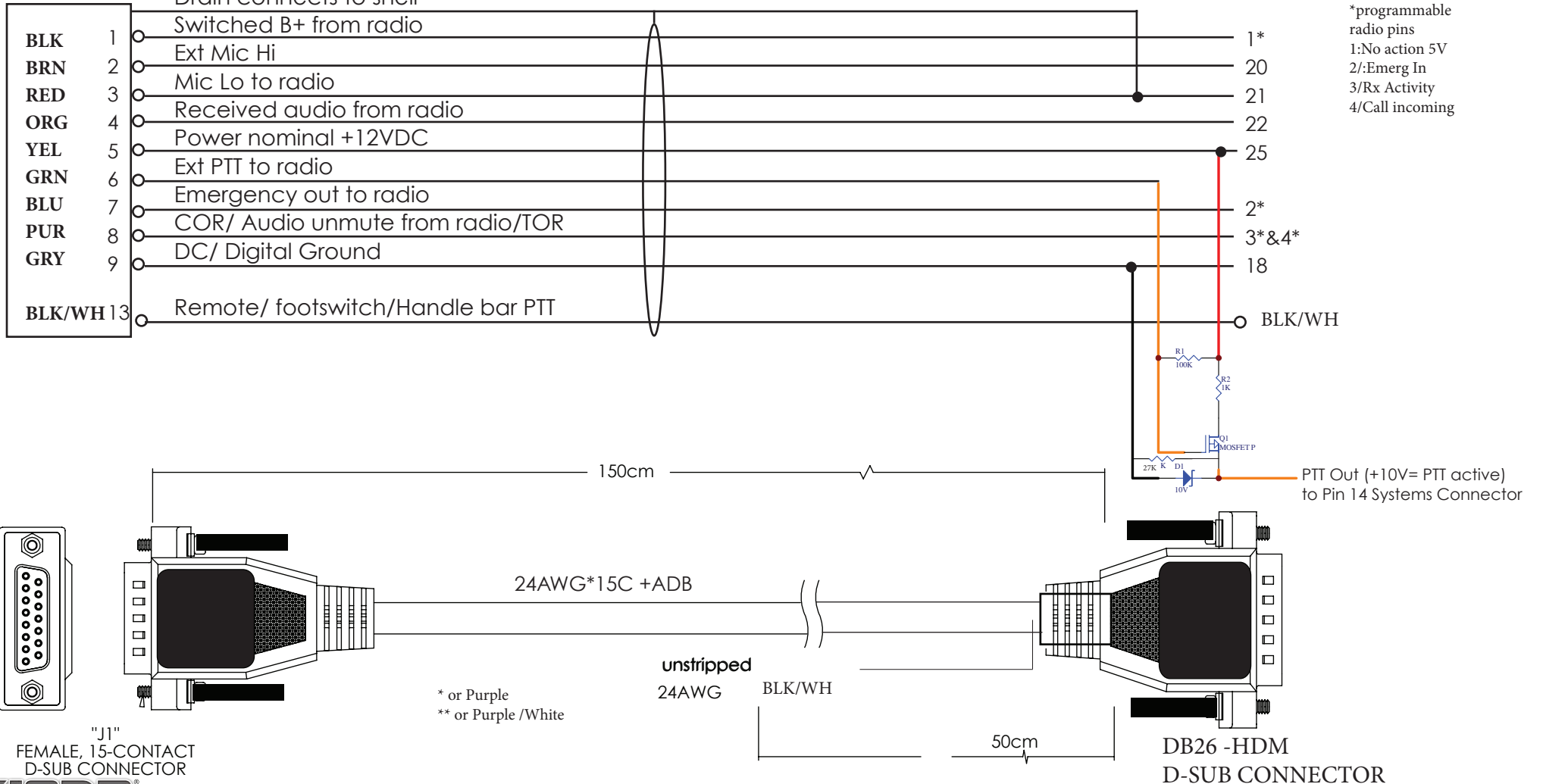

Company Confidential Proprietary

XMC-SRM Interface cable:

for Simoco SRM 9000 series mobiles
 (adds X10DR Interface cable to an existing SRM power cable)
 V2

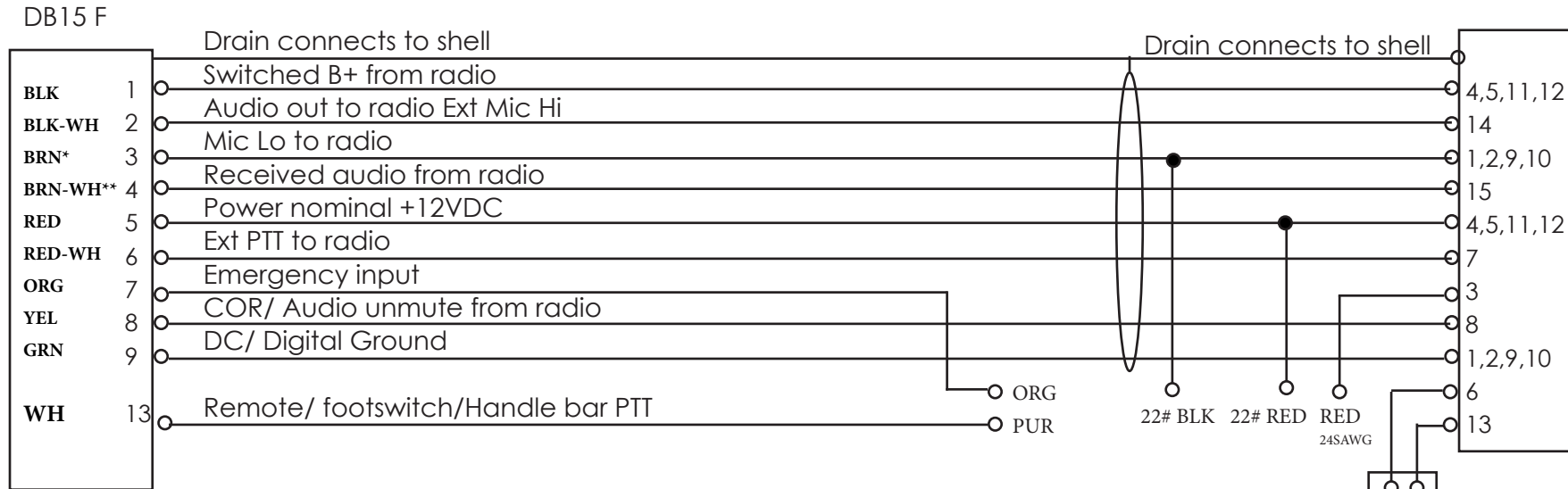

RED 24AWG - normally this is ignition sense input, but some SRM9000 models may be internally modified/jumpered to make this an emergency input. In such cases join RED to Orange.

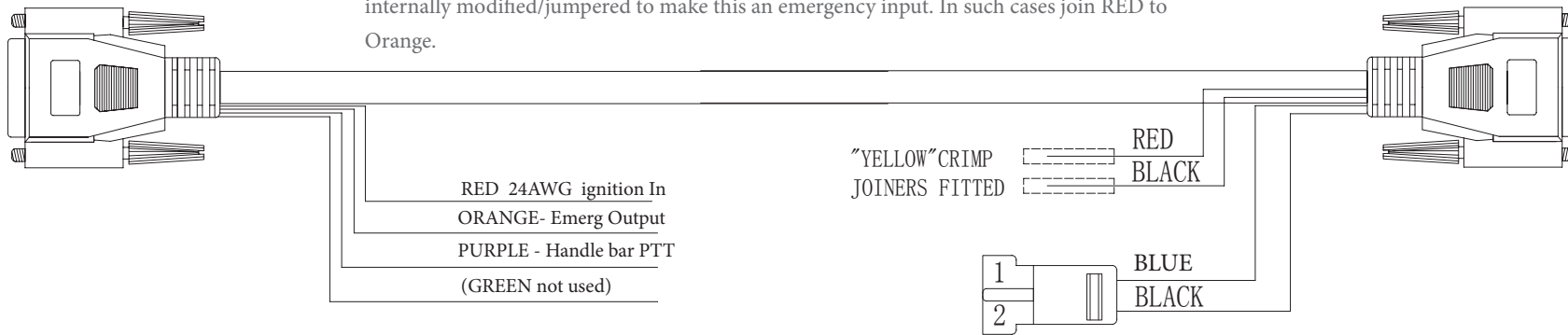

DB15 -M
 D-SUB CONNECTOR



SRM9000 Programming info v0

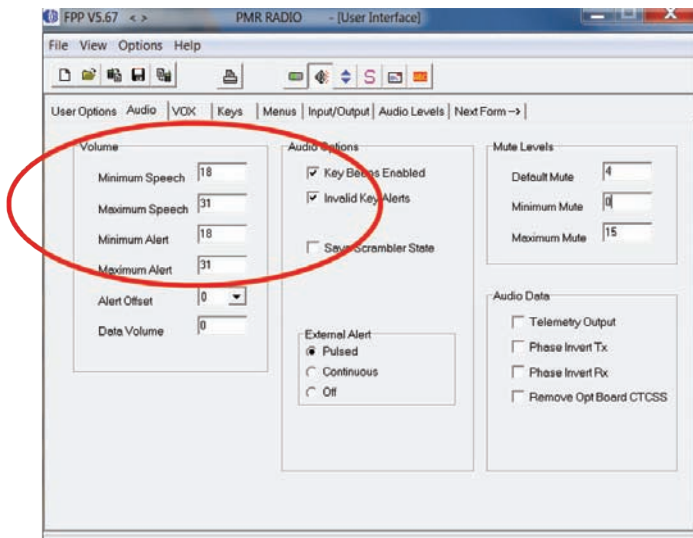
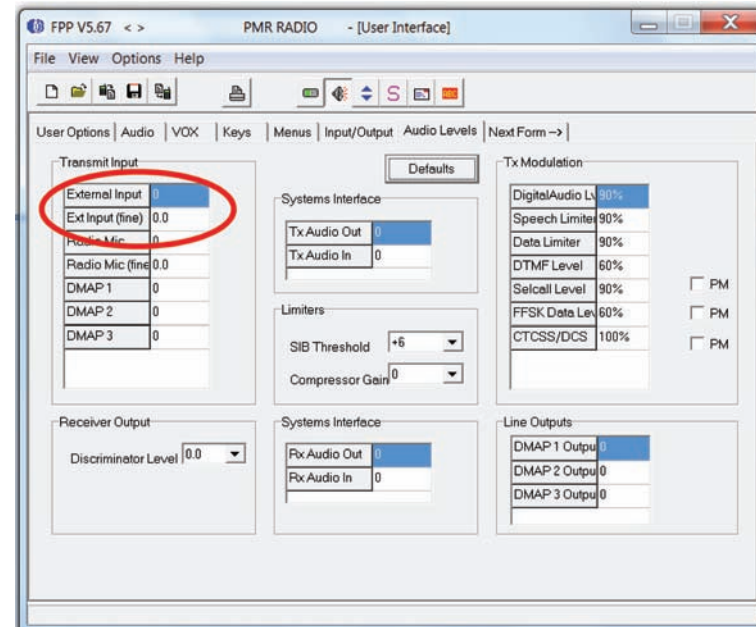
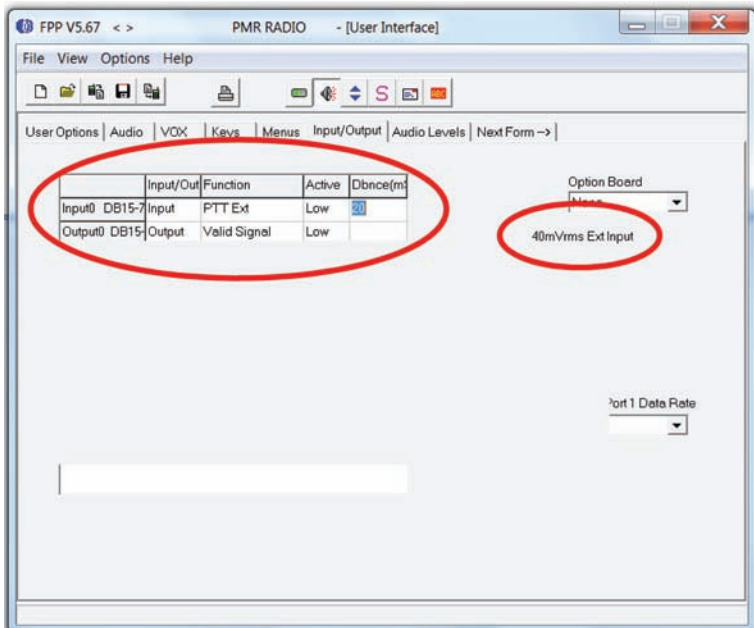

XMC-SRG Interface cable:

for Sepura SRG TETRA series mobiles
(add X10DR to an existing SRG power cable)
V1

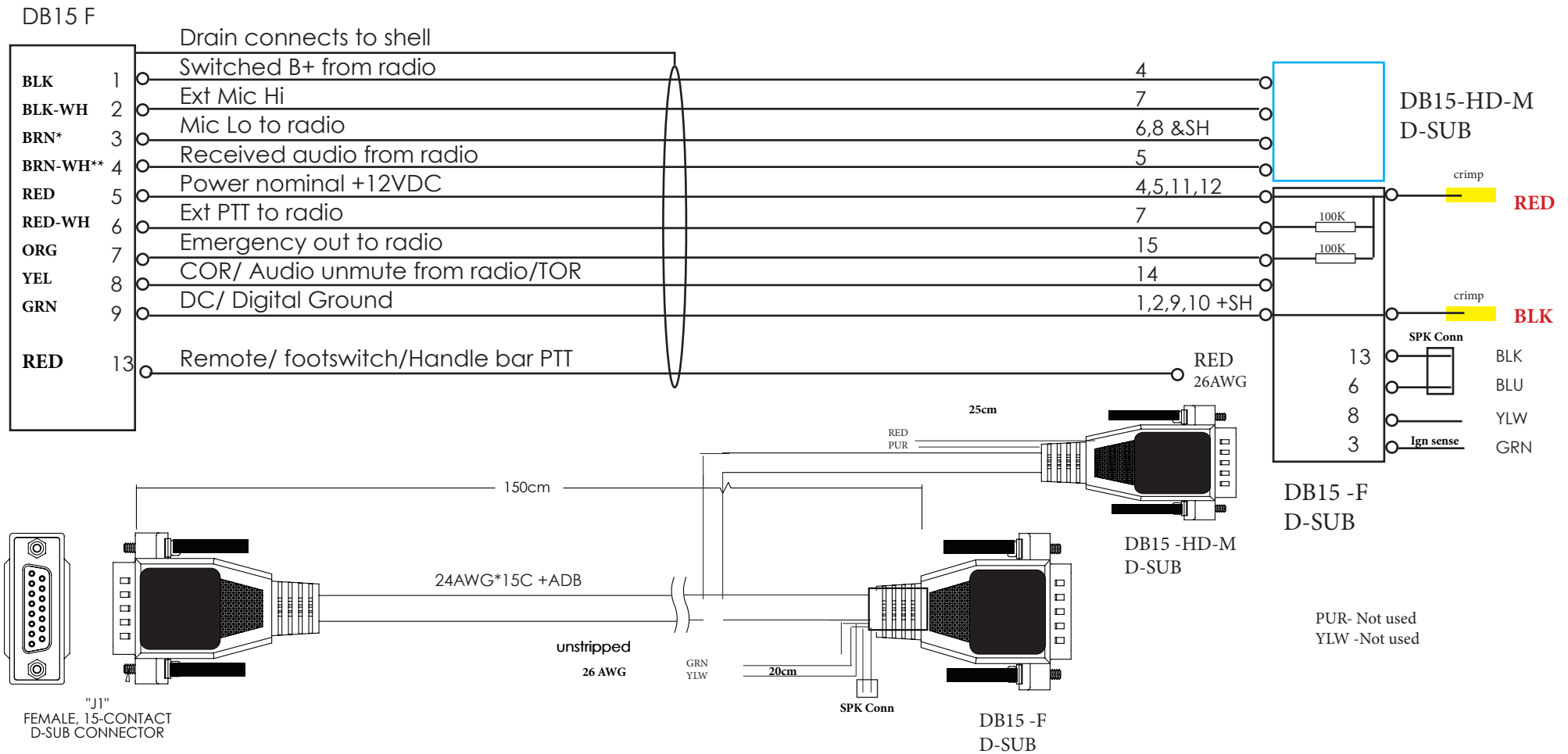

SRG3900 Programming info v0



Audio Presentation

Loudspeaker Gain Relative to Escape	-0dB	Validate
Audio Presentation Flag	<input type="checkbox"/>	Audio Presentation
Duplex Accessory Public State Soft Key Persistence	Duplex Accessory Public State Toggle SK: Persists	
Line Out Source	Rx Audio only	
Line Out Operation	When Line Out Source audio present	
Alert Attenuation Relative to Speech	-0dB	
Volume Control Mode	Independent Console Control	
Gain Setting for Line In Audio	+5dB	
Line In Audio Device Features	<input type="checkbox"/>	

External Digital Outputs

External Alert Operation Digital Output 1	Active for duration of call	Validate
External Alert Operation Digital Output 2	Disabled	Audio Presentation
External Alert Operation Digital Output 3	Disabled	External Digital Outputs
External Alert Activation Time	0	
Alarm External Alert Time	0	

External Digital Inputs

Transceiver External Digital Input 1, + edge	Line In 1 PTT Off (SRG43 only)	Validate
Transceiver External Digital Input 2, + edge	Line In 1 PTT On (SRG43 only)	External Digital Inputs
Transceiver External Digital Input 2, + edge	None	
Transceiver External Digital Input 2, + edge	Alarm	
Transceiver External Digital Input 3, + edge	None	
Transceiver External Digital Input 3, + edge	None	
Console/JBU on Console Interface 1 External Digital Input 1, + edge	None	
Console/JBU on Console Interface 1 External Digital Input 1, + edge	None	
Console/JBU on Console Interface 1 External Digital Input 2, + edge	None	
Console/JBU on Console Interface 1 External Digital Input 2, + edge	None	
Console/JBU on Console Interface 1 External Digital Input 3, + edge	None	
Console/JBU on Console Interface 1 External Digital Input 3, + edge	None	
Console/JBU on Console Interface 1 External Digital Input 3, + edge	None	
Console/JBU on Console Interface 1 External Digital Input 3, + edge	None	
Console/JBU on Console Interface 2 External Digital Input 1, + edge	None	
Console/JBU on Console Interface 2 External Digital Input 2, + edge	None	
Console/JBU on Console Interface 2 External Digital Input 2, + edge	None	
Console/JBU on Console Interface 2 External Digital Input 2, + edge	None	
Console/JBU on Console Interface 2 External Digital Input 3, + edge	None	
Console/JBU on Console Interface 2 External Digital Input 3, + edge	None	

XMC-ORI Interface cable - Harris orion **Draft**

V0

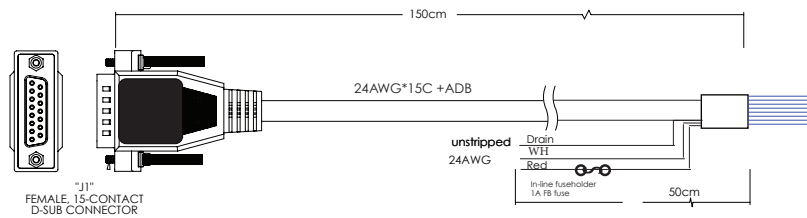
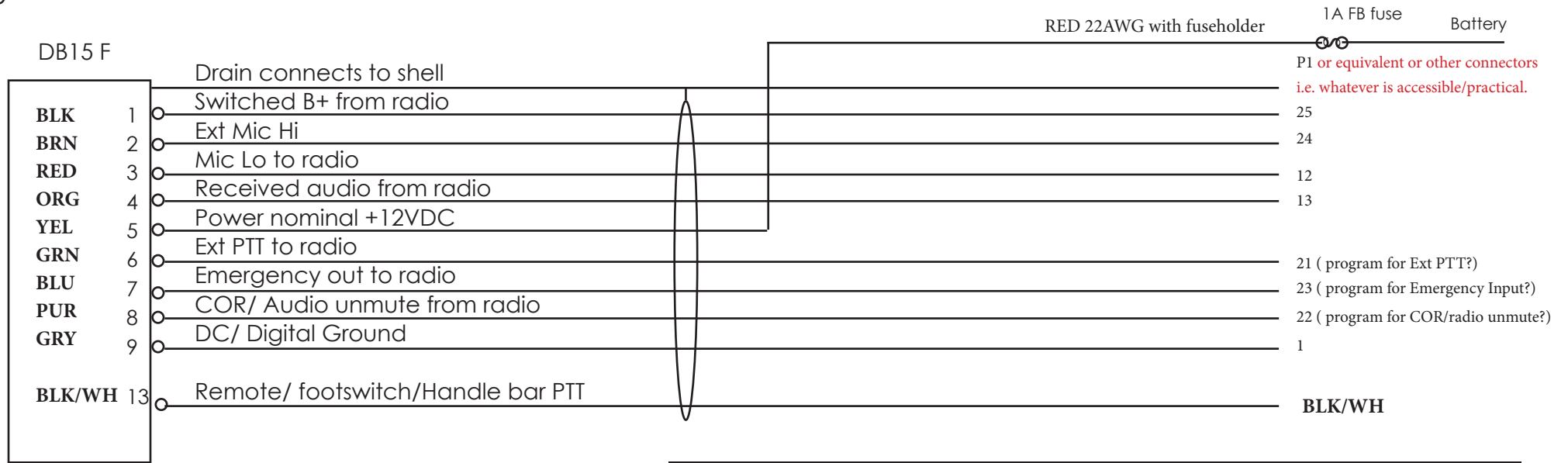

*15" FEMALE, 15-CONTACT D-SUB CONNECTOR

WE HAVE NOT TESTED ON HARRIS ORION MOBILE AS YET BUT BASED ON SUPPLIED DOCUMENTATION SHOULD BE ABLE TO WORK ASSUMING PINS 21,22 1NBD 23 ARE PROGRAMMABLE AS SHOWN.

* or Purple
 ** or Purple /White

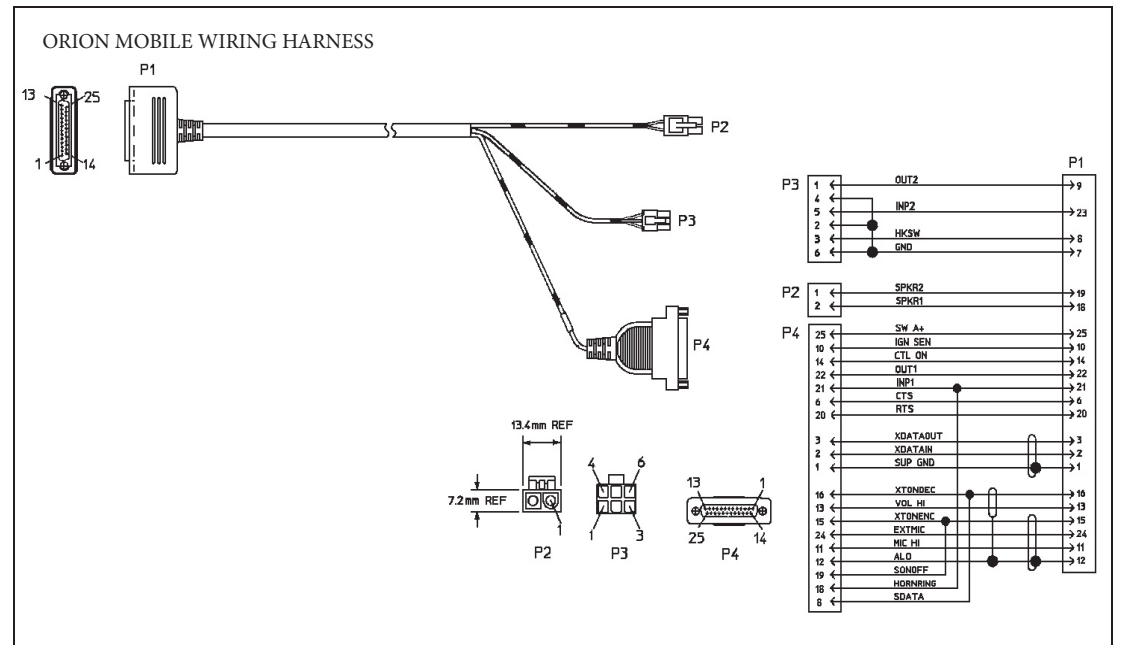

XMC-H26 Interface cable

: for Hytera MD68x Tetra & 78x DMR mobiles

V1 -

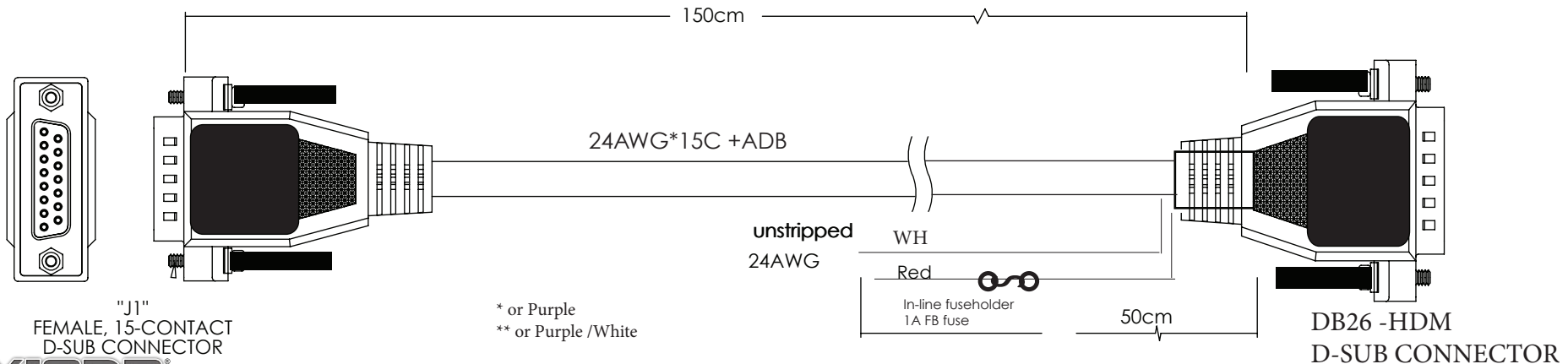
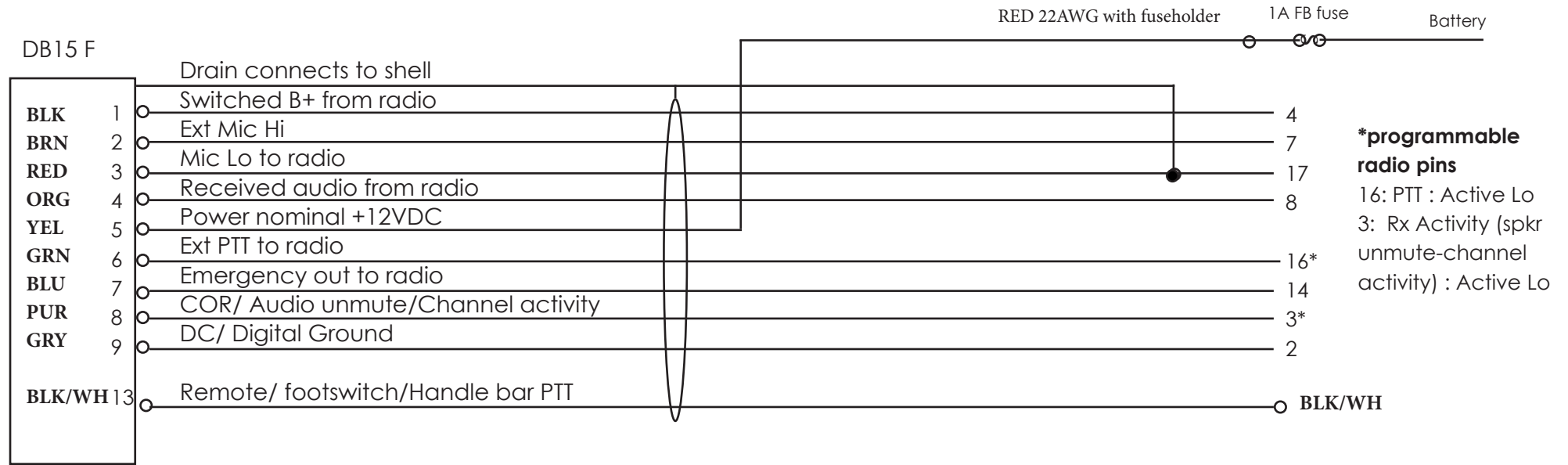

Company Confidential Proprietary



XMC-T26 Interface cable

: for Teltronic MDT400 mobiles (Draft)

V1

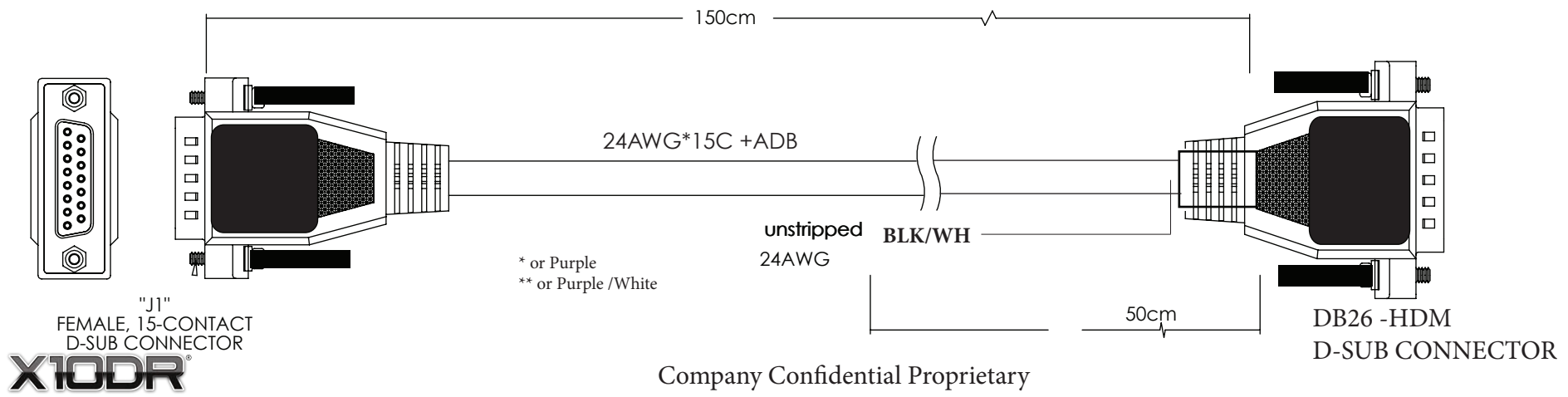
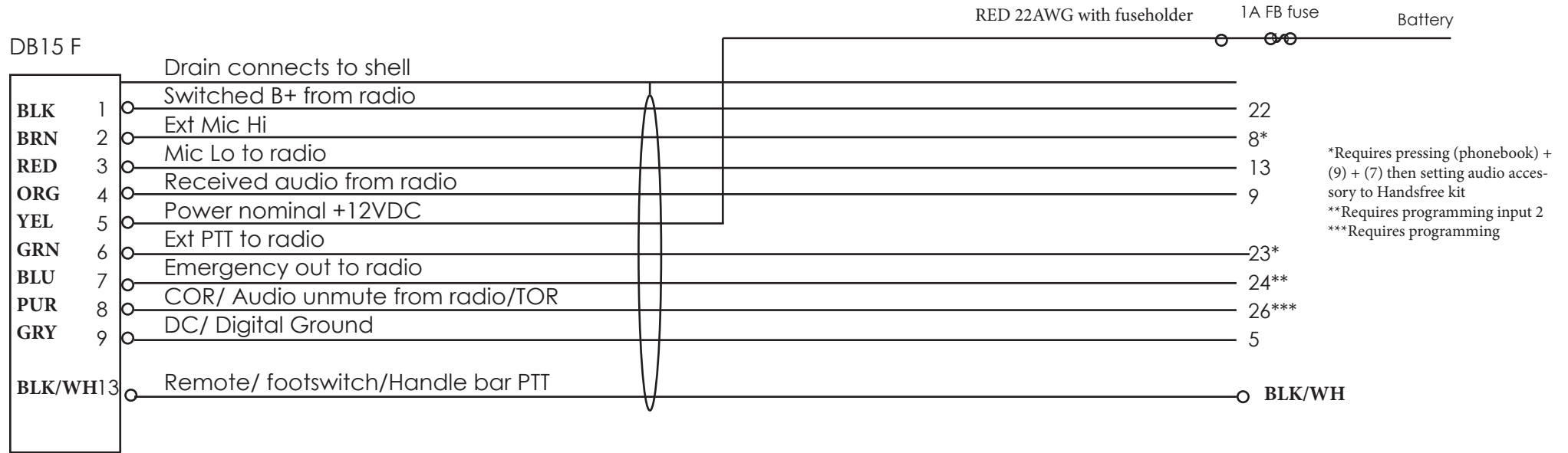

Company Confidential Proprietary

XMC-G25 Interface cable

: for GME P25 models (with DB25 connect)
V0

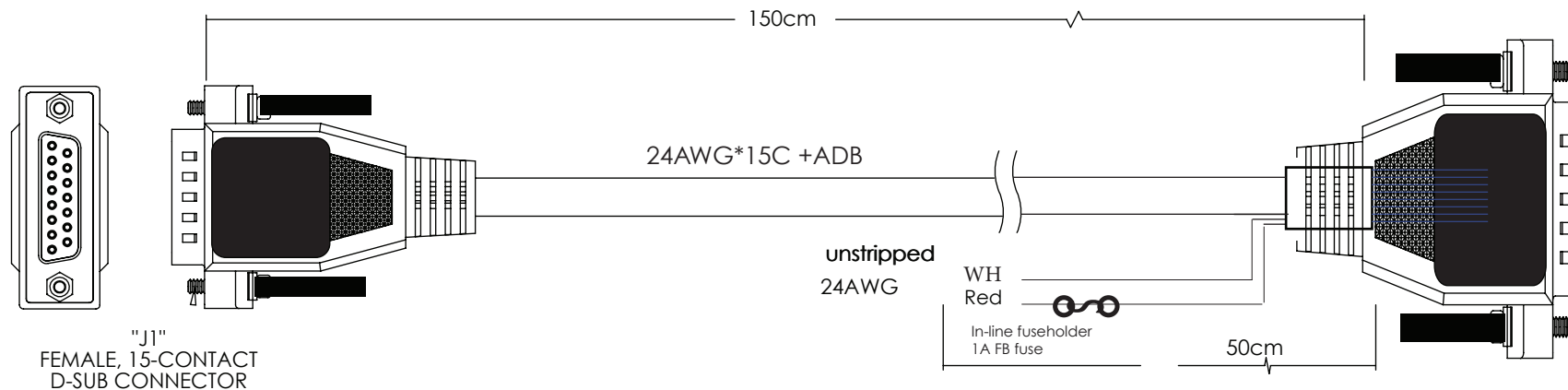
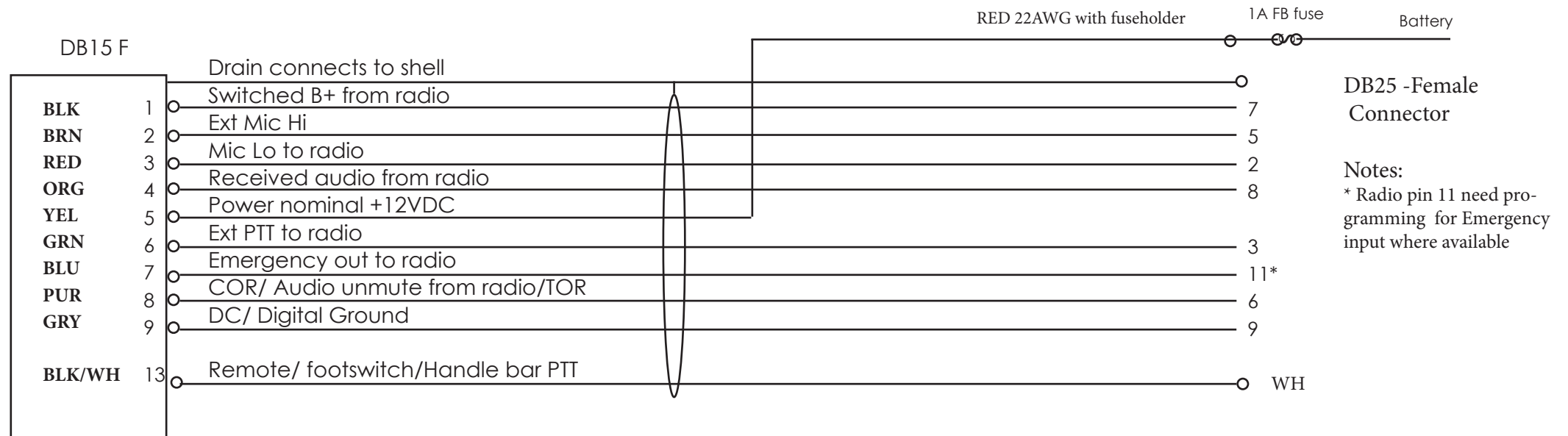

XMC-R15 Interface cable

: for RELM BENDIX KING GMH/DMH mobiles
V1

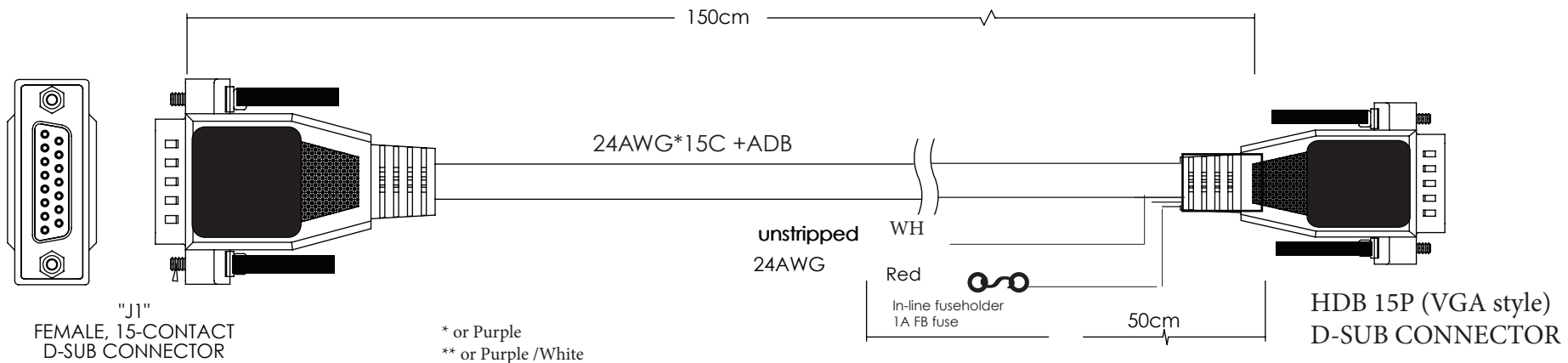
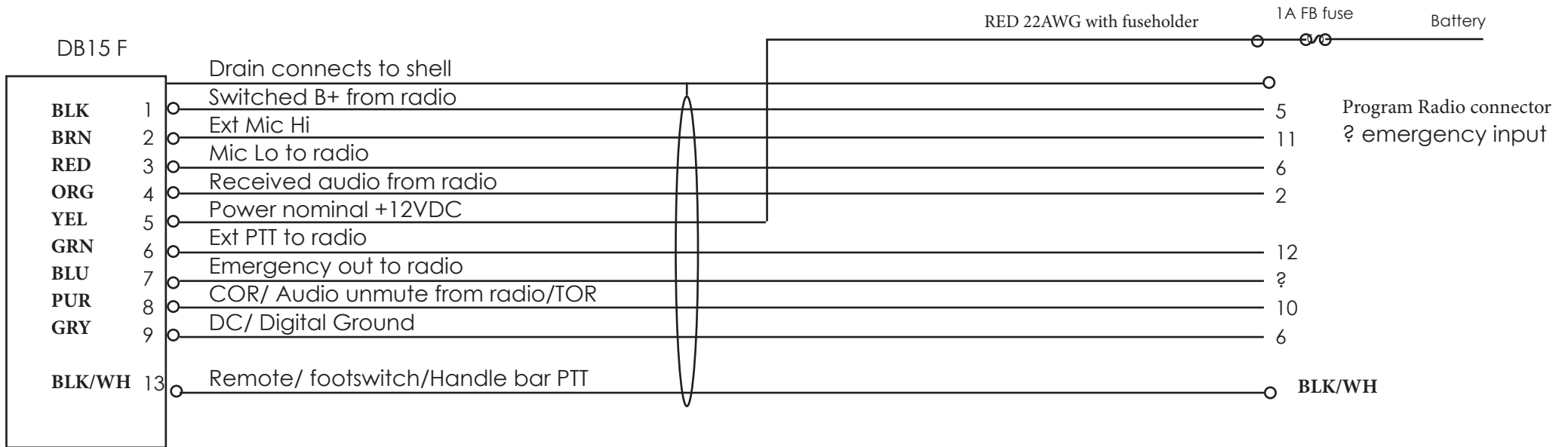

XMC-R25 Interface cable

: for Relm models (with DB25 connector)
V0

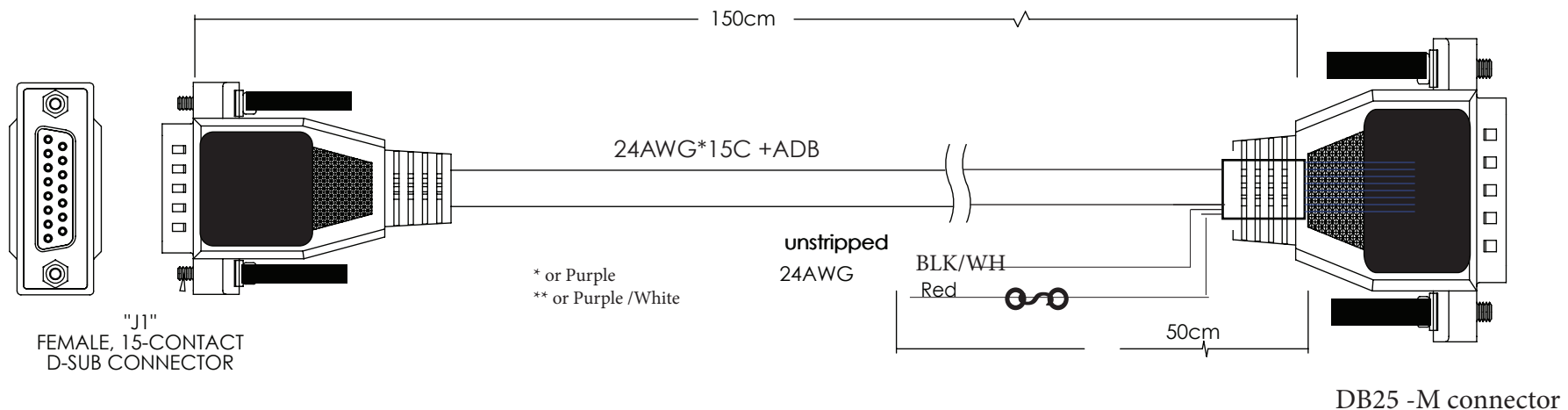
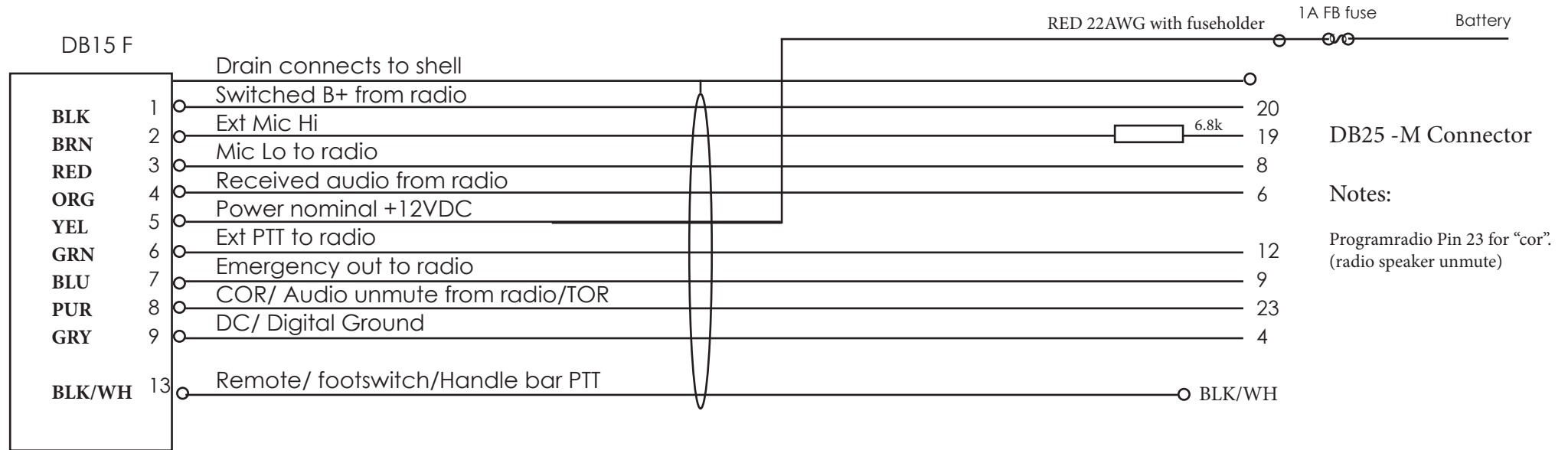

XMC SERIES CABLES - ALTERNATE WIRING COLORS

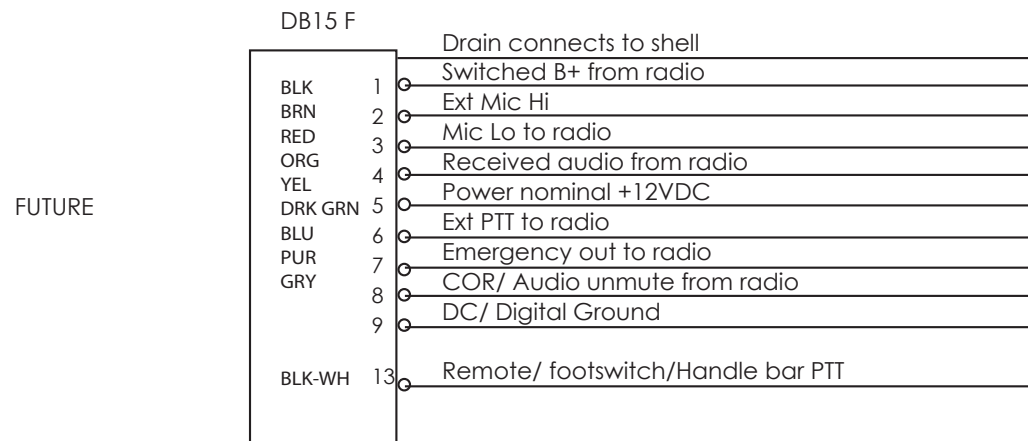
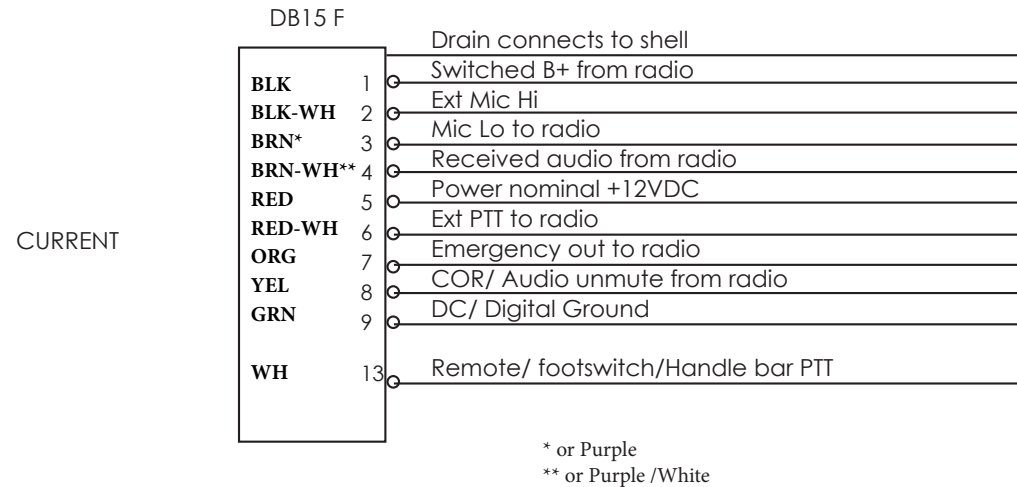

MOTORCYCLE INSTALLATIONS



X10DR has been designed for Motorcycle installations. By ordering either the X10DR-XX1 or the XU1 model with the XHC Hirose audio port option, you have an interface specifically designed to connect to most bike riders helmet audio.

As many organisations globally have adopted their own wiring standards for the helmet audio “down cable”, WCL has a **custom cable service** available to allow custom professionally manufactured interface cable to plug between the X10DR's 6 pin Hirose connector and your existing helmet wiring.

The following drawing provides an overview of how to convert from being “wired to the bike” to instead allow the rider to be untethered for up to 300m from the bike, while remaining in communication with the network.

EXTRA XMC WIRE: that the small extra wire (originally usually WH but now BLK/WH coloured) that you will find on a “XMC-****” is designed to provide remote PTT and this should be wired to the bike's existing handle bar PTT switch and the existing PTT wire to the radio disconnected assuming a wired helmet is no longer required. If you want the option then it may be necessary to remove the existing wire that comes from the handle bar PTT that goes to the radios PTT input and then reconnect that via a toggle switch so user can select “wired or wireless operation.

For most organizations, helmets will already exist with a short wire tail with a *quick release* connector that plugs into a “hard wired to the bike” cable that attaches either directly to the host radio's microphone input and its speaker output, or sometimes, via an external interface box that allows the user to manually or automatically switch to horn speakers when off their bikes.

If it is a permanent changeover with no wired redundancy required, then we suggest you replace the existing helmets down cable's with one that has a Hirose HR10(A)-7P-6P connector, (ideally a molded version but if not, one that will stop water ingress when riding in torrential rain and at high speeds).

Alternatively, if you wish to maintain wired redundancy, then you need to make/buy a short interface cable that correctly connects the existing helmet's Mic Hi and Mic Lo and Spk Hi and Spk Lo to the correct Hirose pins as per the following wiring charts.

CAUTION: To ensure maximum range the bike rider should attach the X10DR to their shoulder area and then make sure cable lengths do not interfere with the riders movements on the bike.



X10DR

Company Confidential Proprietary

Typical Interface cable

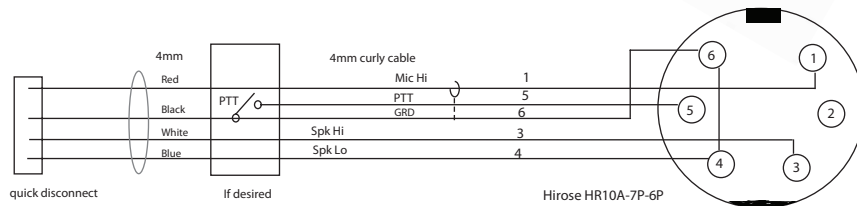

X10DR Hirose input

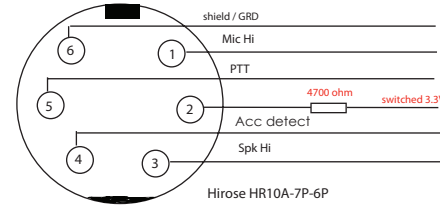

X10DR Hirose input-M/C Bridged audio

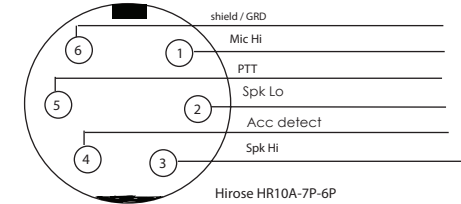

Note: some motorcycle helmets have very low level mic audio out and may require you to set the X10DR to high external mic sensitivity. To do this power up the Secure mic holding the blue top right Volume UP button until the unit finishes sounding its escalating start tones. This will then increase its EXTERNAL mic sensitivity only. If this is insufficient, first reset by powering up again while holding down the top blue left hand side Volume down button. You will then need to use the XPK programming kit to increase the gain setting for "external microphone standard volume" setting to your required level.

In almost all cases that would sufficient but if still too low then a custom down cable with integrated pre-amp may be required.

From April 2014 X10DR spk Mics will be wired as per M/C bridged audio shown above

Typical Helmet down cable wiring

AZDPS Motor Headset Wiring

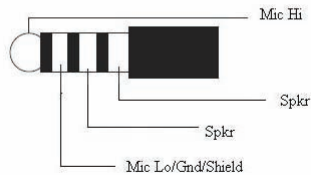

Nexus TP-120/TP-101/U-174/U

Typical interface cable wiring

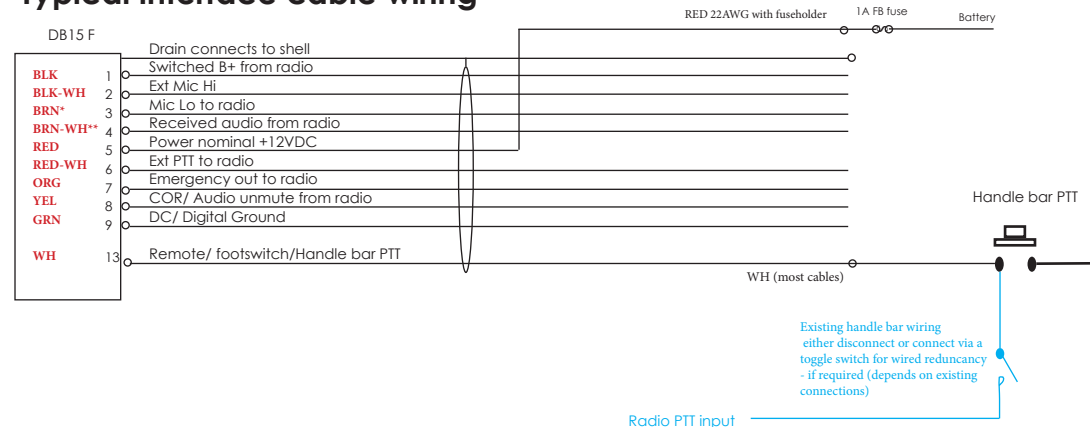

TROUBLESHOOTING



First, re-read pages 2-5 of this document to better understand what each I/O of the X10DR X-ponder 15 pin connector requires for correct operation.

Most problems getting the X10DR to work with your radio usually come down to simple things easily overlooked. These include: -

1/ Forgetting to program or jumper your radio's interface connector to provide the REQUIRED function input/output.
- these may include: enabling Emergency input with active low, enabling COR with active low output, Setting radio RX audio to be muted when radio is squelched, setting External Mic input for analog audio, etc.

2/ Not connecting the right wire to the right pin.
(note do not confuse heatshrunk shield/drain wire with black wire connected to X10DR Pin 1

3/ Failing to set the VR1 trimpot so that X10DR Mic audio level matches the radio's fist mic level.
Some radios such as Kenwood models have a 5 mV input sensitivity. In such cases, you should fit a 8-10K resistor in series with the radio's external mic input to reduce the audio level sent from the X10DR otherwise noise will exist and audio will distort badly.

4/ Failing to set VR2 trimpot so that X10DR speaker level is loud but not distorted.

5 / Not setting the correct polarity for COR input - i.e active low - X10DR Pin 8 input
Default input is active low. Set your radio to suit. If not, fit J3 jumper inside the X-Ponder cradle for active high.

OTHER:

NO COR available:

- leave pin 8 of X10DR input isolated and let X10DR internal VOX create an internal COR function.
- Some radios spk audio output provide a DC shift from 0 hms to mid rail whenever audio becomes active. By shifting the 0 ohm resistor from R41 to R40 inside thje X-Ponder cradle and then connecting the COR input to the radio's speaker audio output use this DC shift to provide COR indicate.

No Switched B+ available:

- fit a manual On/Off switch X10DR Pin 1 to +12V





All rights reserved Wireless Corporation Limited ©2014
Wireless Pacific, X10DR and their logos are trademarks or registered
trademarks of Wireless Corporation Limited. Rev 18

Company Confidential Proprietary